

# Dual Plate Check Valves





## COMPANY PROFILE

1989..Not just a company but a vision was born.. Jayant Valves an ISO 9001 certified company was established in the year 1989. Over the period of three decades since commencing its business activities it has provided its services across a broad spectrum of industries like Oil & Gas, Chemicals, Petrochemicals, Fertilizers, Power Plants, Paper Industries, Refineries, Atomic Energy Plant, Building Equipment, Water and Waste Water Industries. With its conventional valves and ultra modern technologies Jayant Valves has steered its way to its present day position in the market which is being India's top-tier manufacturer and exporter of Industrial Valves. After three decades of serving the demands of a huge market across various sectors, today our product's presence cuts across the length and breadth of India. Ranging from Gate Valve, Globe Valve, Swing Check Valves, Forged Steel Valves, Pressure Seal Valves, Butterfly Valves, Ball Valves, Dual Plate Check Valves, API 6D Valves with significant expertise accumulated over the years today our product range confirms to international standards such as API, ASTM, ANSI, Din, BS, NACE & MSS. Approval from the Indian Boiler Board is a testimony of standards of our in-house manufacturing facilities.

## VALUED CUSTOMERS



02 Profile



04 Wafer End - Retainer Type / Retainer Less  
Size Range : 2" ~ 48"

04 Design Features, Application, Installation

05 Technical Information

06 Dual Plate Check Valve  
ANSI B16.5 - #125, ANSI B16.5 - #150  
Wafer Type Rubber Lined

07 Dual Plate Check Valve  
ANSI B16.5 - #125  
Wafer Type

08 Dual Plate Check Valve  
ANSI B16.5 / B16.47 Series A - #150  
Wafer, Lug & Flange Type



09 Lugged End - Retainer Type / Retainer Less  
Size Range : 2" ~ 10"

09 Dual Plate Check Valve  
ANSI B16.5 - #300  
Wafer, Lug & Flange Type

10 Dual Plate Check Valve  
ANSI B16.5 - #600  
Wafer, Lug & Flange Type

11 Dual Plate Check Valve  
ANSI B16.5 - #900  
Wafer, Lug & Flange Type



12 Flanged End - Retainer Type / Retainer Less  
Size Range : 12" ~ 48"

12 Dual Plate Check Valve  
ANSI B16.5 - #1500  
Wafer, Lug & Flange Type

13 Dual Plate Check Valve  
ANSI B16.5 - #2500  
Wafer, Lug & Flange Type

14 Material Selection Guide

16 Ordering Instruction



18 Hub End - Retainer Type / Retainer Less  
Size Range : 2" ~ 20"

18 Hub End Check Valve



## DESIGN FEATURES

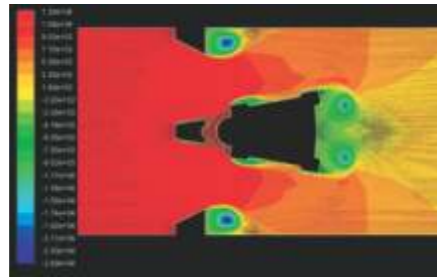
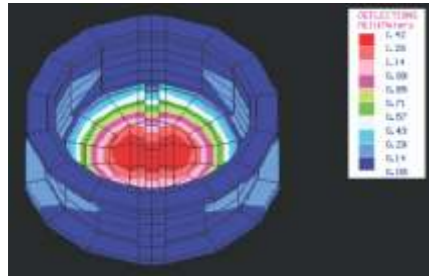

- Design by Wire
- FEM Stress Analysis

- CFD - Computational Fluid Dynamic Software helps to achieve Low Pressure Drop ( $\Delta P$ ), high Cv design

- Retainerless Design is intrinsically **FIRE SAFE**
- Stellite Lapped seat
- High Performance Spring Design
- Shock Bumper Prevents Slamming with Spring and Pins
- Serrated Finish 125 - 250 AARH or RTJ as per requirement
- No Fugitive Emission

## APPLICATION

- In downstream of pump preventing flow reverser
- In Wellhead injection Lines, for Oil Rigs and Platforms
- In Gas and Oil Processing plants and refinery on Delivery/Discharge side of pumps
- For LNG and Chemical storage tank, use on discharge side of pump to prevent backflow

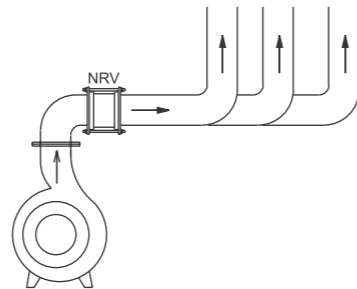

## INSTALLATION

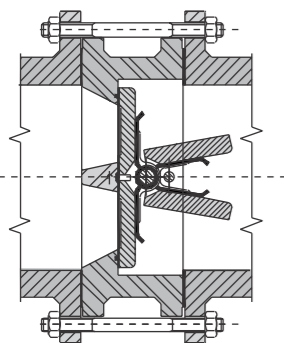

Wafer Design

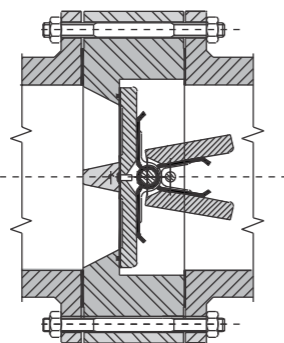

Solid Lug Design

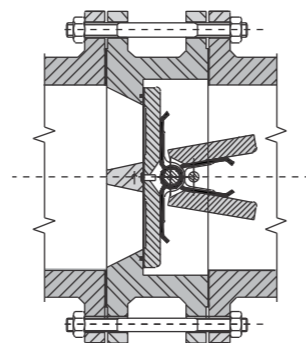

Flanged Design



## TECHNICAL INFORMATION

### Pressure Drop Information

- The curves show pressure drops available with standard torque Springs and the Dual Plate Check Valve in horizontal flow
- Dual Plate Check Valves should be installed in horizontal flow with pins Vertical for best performance. For other installations, Contact the Factory
- We can Size Dual Plate Check Valves relative to your system Parameter

### Valve Life V/S. Cost V/S. Energy Saved

All these aspects are quite inter-related. The mathematical Expression for energy saved  
 Power Saved = Difference of Power Consumed (kw) x Cost per kw

$$\frac{\text{The Difference Of Power Consumed (kw)}}{\text{Consumed (kw)}} = \frac{\text{H.P.} \times \text{Head Difference} \times \text{Wt. of Liquid per min.} \times 0.76}{33,000}$$

The above Head difference in feet of water column  
 Wt. in lbs  
 H.P. is British Horse Power

### Cv Value

Cv is defined as the quantity of fluid measured in U.S. Gallons per Min. When the Pressure drop across the valve is maintained at 1 psi.  
 The relation between Flow & Pressure drop is expressed as

$$Q = Cv \sqrt{\frac{\Delta P}{G}} \quad \begin{matrix} Q = \text{Flow in U.S. Galleons per min.} \\ Cv = \text{Valve Co-efficient} \end{matrix} \quad \begin{matrix} P = \text{Differential Pressure in psi.} \\ G = \text{Specific gravity of Fluid} \end{matrix}$$

### Pressure Drop Curve

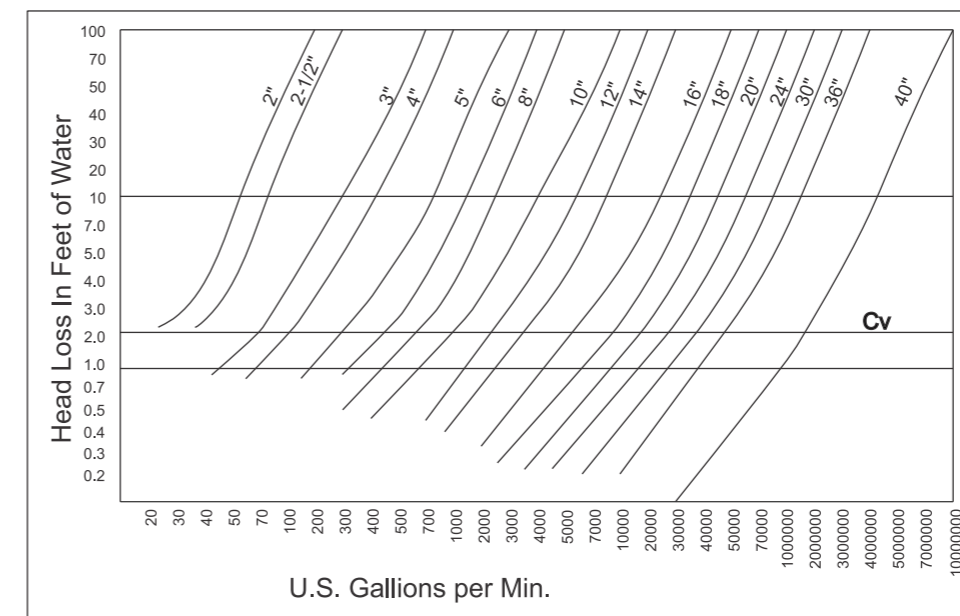

### Cv Value

Valve Inch	Size mm	Class 150-300
2"	50	75
2 1/2"	65	95
3"	80	191
4"	100	377
5"	125	483
6"	150	821
8"	200	1,590
10"	250	2,920
12"	300	4,470
14"	350	5,870
16"	400	8,690
18"	450	10,940
20"	500	14,290
24"	600	23,000
30"	750	37,200
36"	900	59,000
42"	1050	92,000
48"	1200	126,000

# DUAL PLATE CHECK VALVE

## ANSI # 125

**Features** : Rubber Lined  
**Size** : 2" ~ 24"  
**Rating** : ANSI # 125

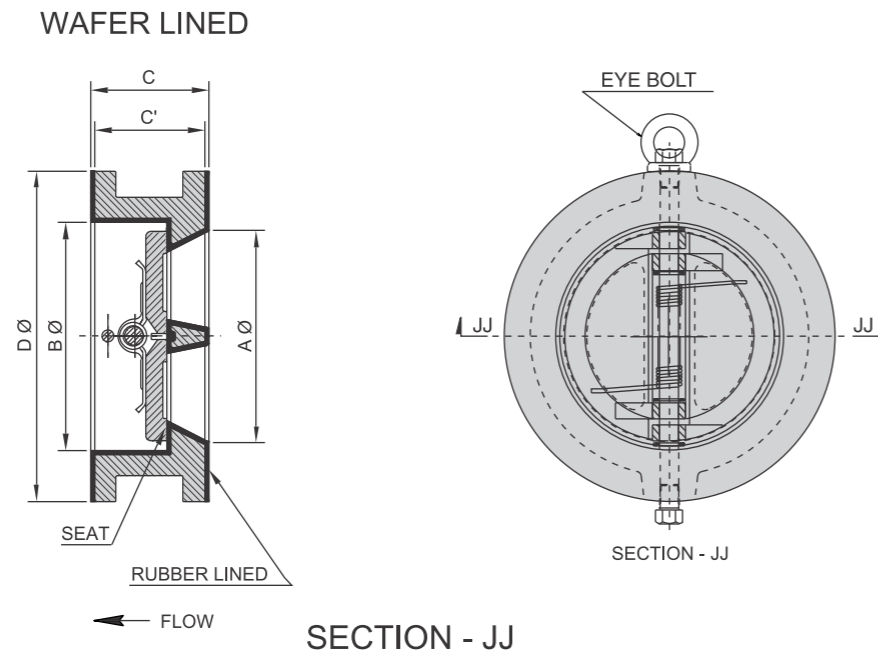

### Installation Dimensions

SIZE Inches (DN)	AØ	BØ	C	C'	DØ	End Facing	Approx weight in Kg. Wafer
2" (50)	50	60	60	54	105	SF	3
2.5" (65)	65	75	66	60	124	SF	5
3" (80)	76	90	73	67	134	SF	7
4" (100)	100	114	73	67	172	SF	9
5" (125)	125	135	89	83	196	SF	14
6" (150)	150	168	101	95	222	SF	16
8" (200)	200	215	133	127	279	SF	26
10" (250)	250	265	146	140	340	SF	48
12" (300)	300	315	187	181	409	SF	78
14" (350)	350	365	190	184	450	SF	90
16" (400)	400	418	197	191	514	SF	100
18" (450)	450	470	209	203	549	SF	140
20" (500)	500	520	219	213	603	SF	180
24" (600)	600	620	228	222	718	SF	210

# DUAL PLATE CHECK VALVE

## ANSI # 125

**Features** : Retainer Type / Retainer Less  
**Size** : 2" ~ 24"  
**Rating** : ANSI # 125

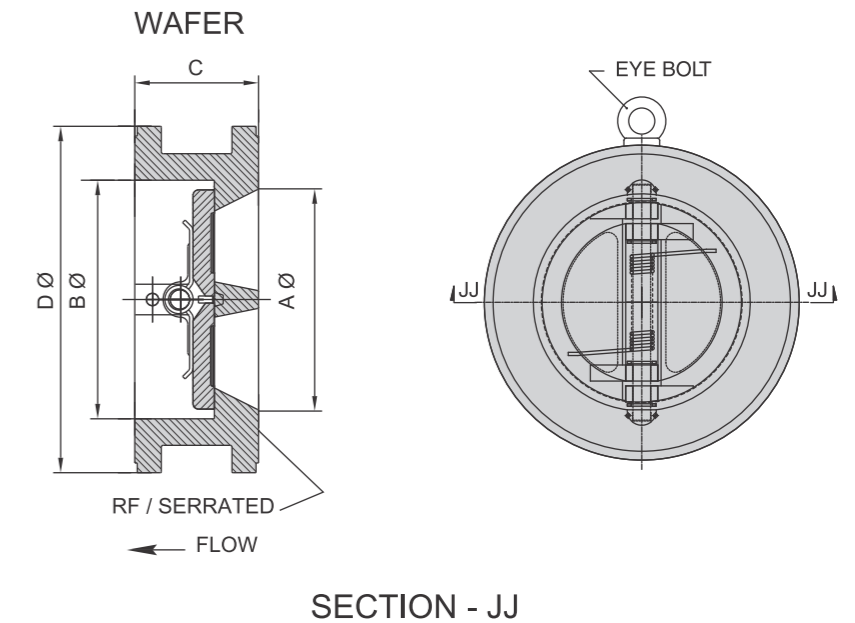

### Installation Dimensions

SIZE Inches (DN)	AØ mm	BØ mm	C mm	DØ Wafer mm	End Facing	Approx Weight In kg. Wafer
2" (50)	50	60	54	105	RF/Serrated	3
2.5" (65)	65	75	54	124	RF/Serrated	5
3" (80)	76	90	57	134	RF/Serrated	7
4" (100)	100	114	64	172	RF/Serrated	9
5" (125)	125	135	70	196	RF/Serrated	14
6" (150)	150	168	76	222	RF/Serrated	16
8" (200)	200	215	95	279	RF/Serrated	26
10" (250)	250	265	108	340	RF/Serrated	48
12" (300)	300	315	143	409	RF/Serrated	78

SIZE Inches (DN)	AØ mm	BØ mm	C mm	DØ Wafer mm	End Facing	Approx Weight In kg. Wafer
14" (350)	350	365	184	450	RF/Serrated	90
16" (400)	400	418	191	514	RF/Serrated	100
18" (450)	450	470	203	549	RF/Serrated	140
20" (500)	500	520	213	603	RF/Serrated	180
24" (600)	600	620	222	718	RF/Serrated	210

1. Size: 2" to 12", Face To Face Dimension 'C' As Per Manufacturers Standard 2. Installation between ANSI B16.5 Flanges

# DUAL PLATE CHECK VALVE

## ANSI # 150

**Features** : Retainer Type / Retainer Less  
**Size** : 2" ~ 48"  
**Rating** : ANSI # 150

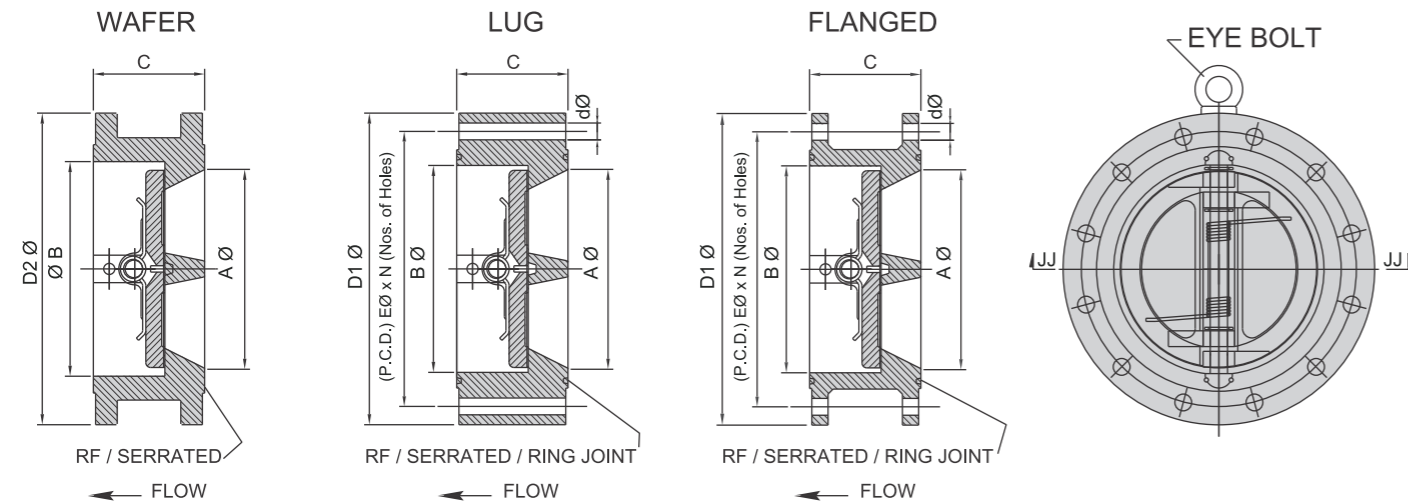

SECTION - JJ

### Installation Dimensions

Size: 2" to 48"

Rating: ANSI #150

Flange: ANSI B16.5 / B 16.47

Size Inches (DN)	Aø mm	Bø mm	C mm	D1ø Lug/Flg. mm	D2ø Wafer mm	Eø P.C.D. mm	N	dø mm	End Facing	Approx Weight In kg.		
										Wafer	Lug	Flanged
2" (50)	50	60	60	152.4	105	120.6	4	19	RF/Serrated	3	7	-
2.5" (65)	65	75	67	177.8	124	139.7	4	19	RF/Serrated	5	12	-
3" (80)	76	90	73	190.5	134	152.4	4	19	RF/Serrated	7	12	-
4" (100)	100	114	73	228.6	172	190.5	8	19	RF/Serrated	9	19	-
5" (125)	125	135	83	254.0	196	215.9	8	22	RF/Serrated	14	25	-
6" (150)	150	168	98	279.4	222	241.3	8	22	RF/Serrated	16	32	-
8" (200)	200	225	127	342.9	279	298.4	8	22	RF/Serrated	26	63	-
10" (250)	250	274	146	406.4	340	362.0	12	25	RF/Serrated	48	93	-
12" (300)	300	325	181	482.6	409	431.8	12	25	RF/Serrated	78	-	125
14" (350)	337	365	184	533.4	450	476.2	12	29	RF/Serrated	90	-	144
16" (400)	387	418	191	596.9	514	539.7	16	29	RF/Serrated	100	-	176
18" (450)	432	432	203	635.0	549	577.8	16	32	RF/Serrated	140	-	210
20" (500)	489	489	219	698.5	603	635.0	20	32	RF/Serrated	180	-	270
24" (600)	591	620	222	812.8	718	749.3	20	35	RF/Serrated	274	-	380
30" (750)	642	695	305	984.3	882	914.4	28	35	RF/Serrated	625	-	790
36" (900)	900	936	368	1168.4	1048	1085.9	32	41	RF/Serrated	980	-	1140
42" (1050)	1050	1070	432	1346.2	1219	1257.3	36	41	RF/Serrated	1250	-	1900
48" (1200)	1200	1200	524	1511.3	1384	1422.4	44	41	RF/Serrated	2150	-	3350

# DUAL PLATE CHECK VALVE

## ANSI # 300

**Features** : Retainer Type / Retainer Less  
**Size** : 2" ~ 24"  
**Rating** : ANSI # 300

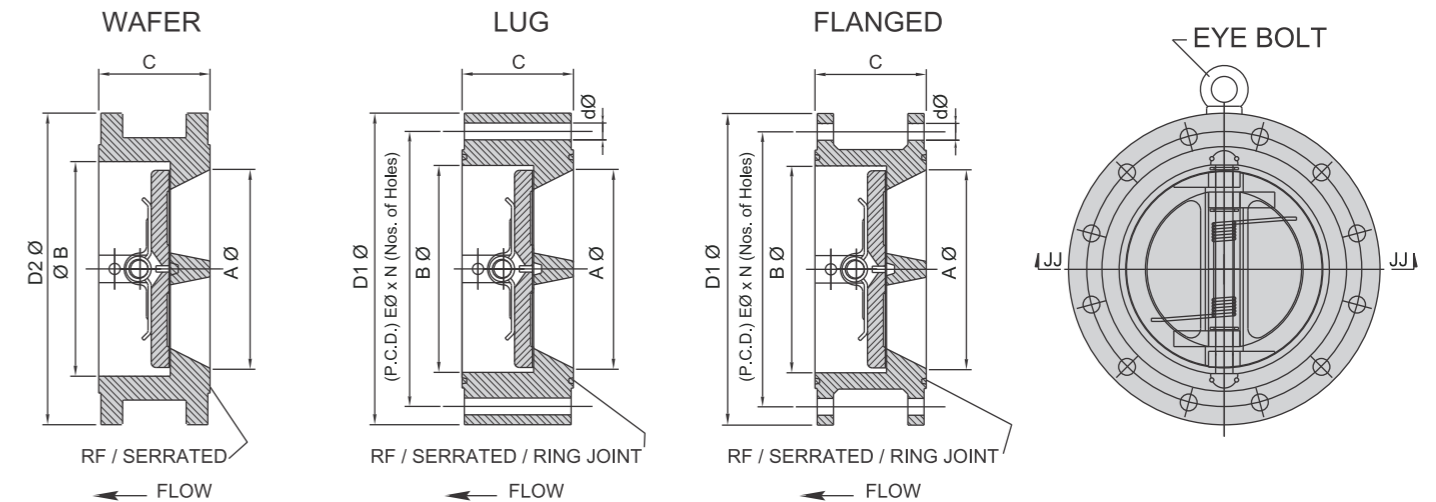

SECTION - JJ

### Installation Dimensions

Size: 2" to 24"

Rating: ANSI #300

Flange: ANSI B16.5

Size Inches (DN)	Aø mm	Bø mm	C mm	D1ø Lug/Flg. mm	D2ø Wafer mm	Eø P.C.D. mm	N	dø mm	End Facing	Approx Weight In kg.		
										Wafer	Lug	Flanged
2" (50)	50	60	60	152.4	105	120.6	4	19	RF/Serrated	3	7	-
2.5" (65)	65	75	67	177.8	124	139.7	4	19	RF/Serrated	5	12	-
3" (80)	76	90	73	190.5	134	152.4	4	19	RF/Serrated	7	12	-
4" (100)	100	114	73	228.6	172	190.5	8	19	RF/Serrated	9	19	-
5" (125)	125	135	83	254.0	196	215.9	8	22	RF/Serrated	14	25	-
6" (150)	150	168	98	279.4	222	241.3	8	22	RF/Serrated	16	32	-
8" (200)	200	225	127	342.9	279	298.4	8	22	RF/Serrated	26	63	-
10" (250)	250	274	146	406.4	340	362.0	12	25	RF/Serrated	48	93	-
12" (300)	300	325	181	482.6	409	431.8	12	25	RF/Serrated	78	-	125
14" (350)	337	365	184	533.4	450	476.2	12	29	RF/Serrated	90	-	144
16" (400)	387	418	191	596.9	514	539.7	16	29	RF/Serrated	100	-	176
18" (450)	432	432	203	635.0	549	577.8	16	32	RF/Serrated	140	-	210
20" (500)	489	489	219	698.5	603	635.0	20	32	RF/Serrated	180	-	270
24" (600)	591	620	222	812.8	718	749.3	20	35	RF/Serrated	274	-	380



# DUAL PLATE CHECK VALVE

## ANSI # 600

**Features** : Retainer Type / Retainer Less  
**Size** : 2" ~ 24"  
**Rating** : ANSI # 600

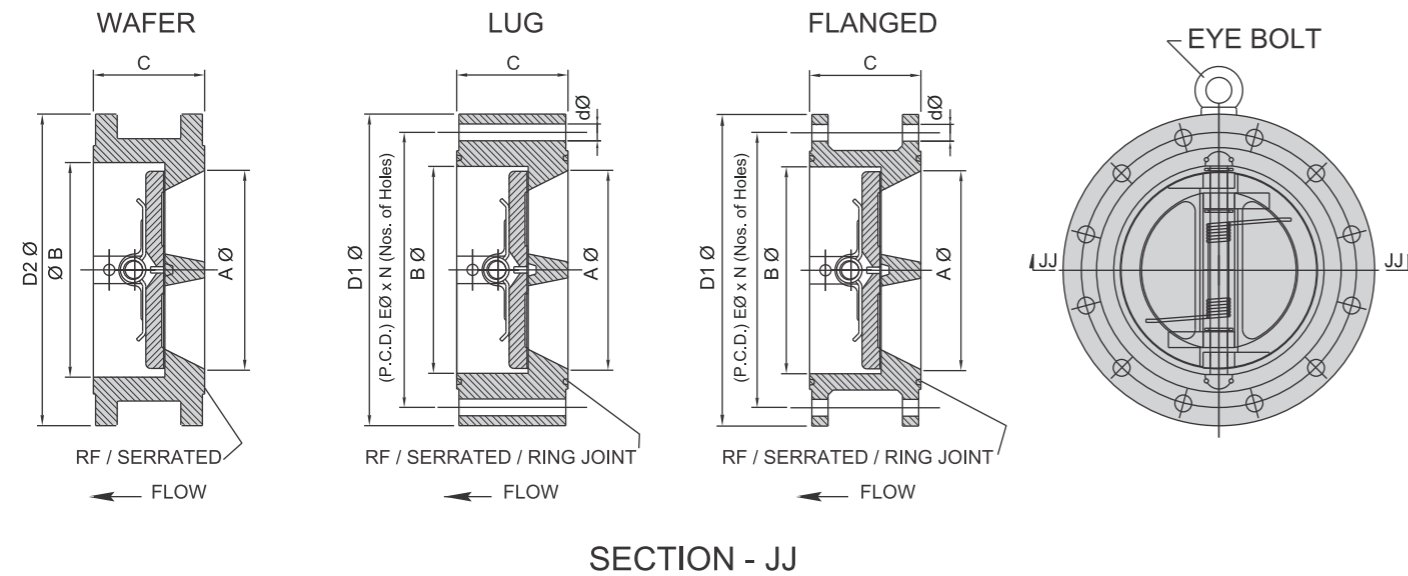

### Installation Dimensions

Size: 2" to 24"

Rating: ANSI #600

Flange: ANSI B16.5

Size Inches (DN)	A mm	B mm	C mm	D1 Lug/Flg. mm	D2 Wafer mm	E P.C.D. mm	N	d mm	End Facing	Approx Weight In kg.		
										Wafer	Lug	Flanged
2" (50)	50	60	60	165.0	111	127.0	8	19	RF / R23	3.5	8	-
3" (80)	76	90	73	209.5	148	168.3	8	22	RF / R31	8	14	-
4" (100)	100	114	79	273.0	193	215.9	8	25	RF / R37	12	30	-
6" (150)	150	168	136	355.6	266	292.1	12	29	RF / R45	32	80	-
8" (200)	200	215	165	419.1	320	349.2	12	32	RF / R49	70	132	-
10" (250)	250	265	213	508.0	400	431.8	16	35	RF / R53	112	234	-
12" (300)	300	325	229	558.8	457	488.9	20	35	RF / R57	160	-	238
14" (350)	327	327	273	603.25	492	527.0	20	38	RF / R61	184	-	378
16" (400)	375	418	305	685.8	565	603.2	20	41	RF / R65	332	-	451
18" (450)	419	419	362	742.9	612	654.0	20	44	RF / R69	390	-	598
20" (500)	464	464	368	812.8	682	723.9	24	44	RF / R73	540	-	762
24" (600)	559	559	438	939.8	790	838.2	24	51	RF / R77	816	-	1142

# DUAL PLATE CHECK VALVE

## ANSI # 900

**Features** : Retainer Type / Retainer Less  
**Size** : 2" ~ 24"  
**Rating** : ANSI # 900

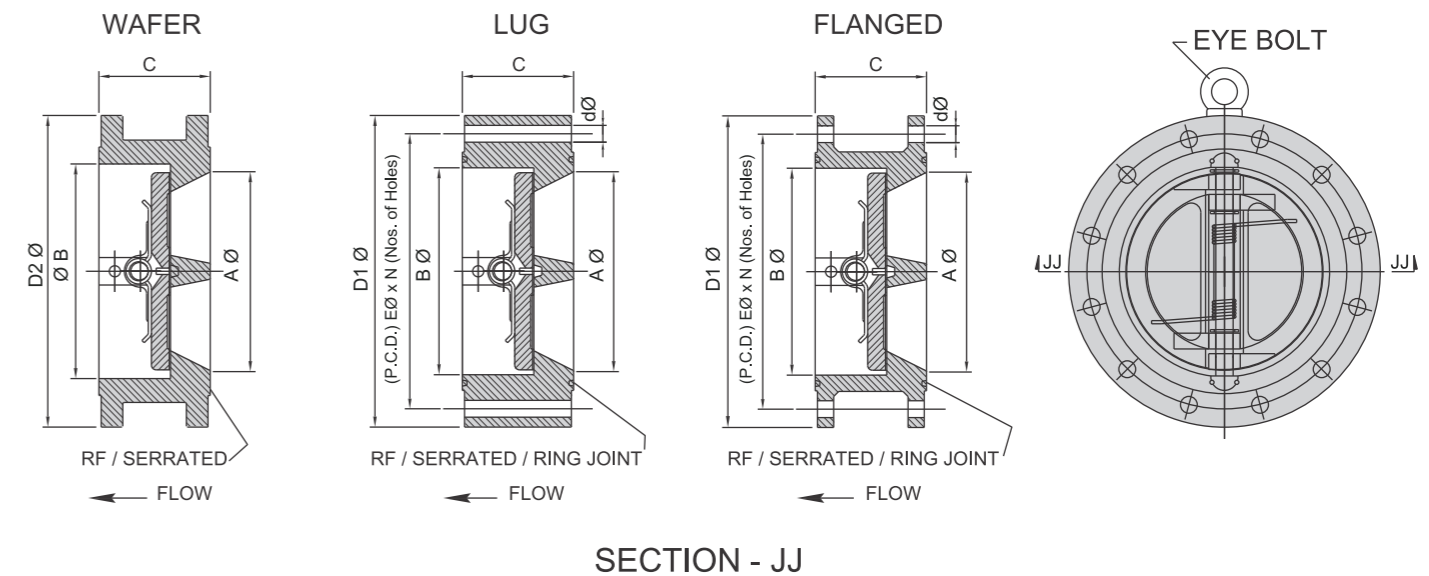

### Installation Dimensions

Size: 2" to 24"

Rating: ANSI #900

Flange: ANSI B16.5

Size Inches (DN)	A mm	B mm	C mm	D1 Lug/Flg. mm	D2 Wafer mm	E P.C.D. mm	N	d mm	End Facing	Approx Weight In kg.		
										Wafer	Lug	Flanged
2" (50)	50	60	70	216.0	142	165.1	8	25	RF / R24	8.5	16	-
3" (80)	76	90	83	241.3	168	190.5	8	25	RF / R31	12	25	-
4" (100)	100	114	102	292.1	206	235.0	8	32	RF / R37	19	45	-
6" (150)	150	168	159	381.0	288	317.5	12	32	RF / R45	54	115	-
8" (200)	200	215	206	469.9	358	393.7	12	38	RF / R49	122	217	-
10" (250)	250	265	241	546.1	434	469.9	16	38	RF / R53	196	330	-
12" (300)	300	315	292	609.6	498	533.4	20	38	RF / R57	292	-	347
14" (350)	350	365	356	641.3	520	558.8	20	41	RF / R62	396	-	560
16" (400)	400	418	384	704.8	574	616.0	20	44	RF / R66	532	-	647
18" (450)	450	470	451	787.4	638	685.8	20	51	RF / R70	611	-	835
20" (500)	500	520	451	857.2	698	749.3	20	54	RF / R74	638	-	1783
24" (600)	600	620	495	1041.4	838	901.7	20	67	RF / R78	1230	-	1888

# DUAL PLATE CHECK VALVE

## ANSI # 1500

**Features** : Retainer Type / Retainer Less  
**Size** : 2" ~ 24"  
**Rating** : ANSI # 1500

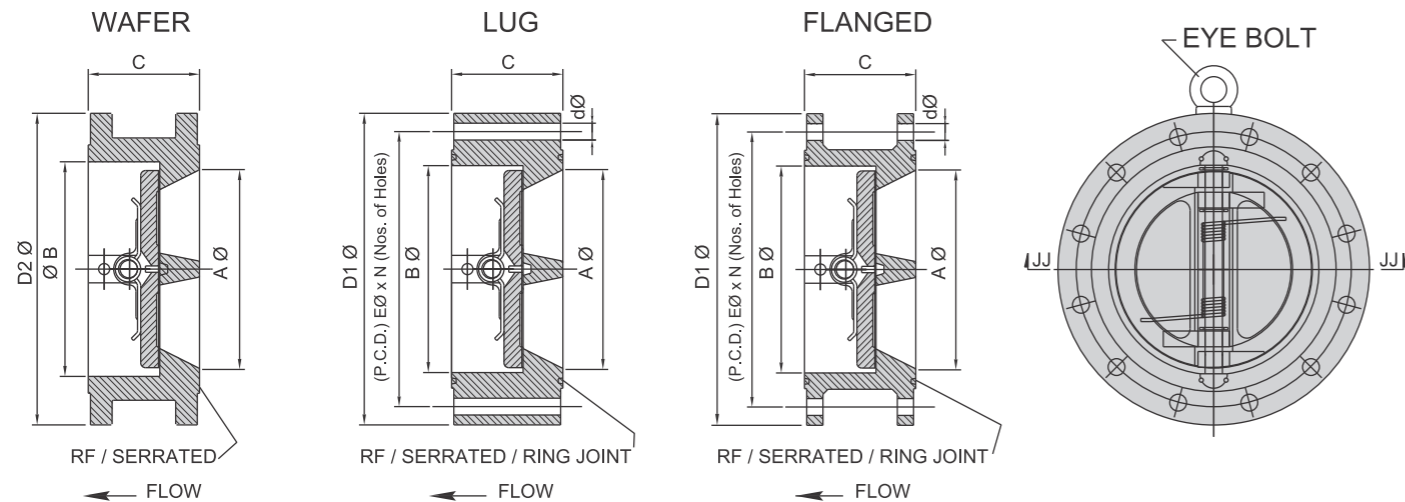

SECTION - JJ

### Installation Dimensions

Size: 2" to 24"

Rating: ANSI #1500

Flange: ANSI B16.5

Size Inches (DN)	Aø mm	Bø mm	C mm	D1ø Lug/Flg. mm	D2ø Wafer mm	Eø P.C.D. mm	N	dø mm	End Facing	Approx Weight In kg.		
										Wafer	Lug	Flanged
2" (50)	50	60	70	216.0	142	165.1	8	25.0	RF / R24	8.5	16	-
3" (80)	76	90	83	266.7	174	203.2	8	31.75	RF / R35	11	29	-
4" (100)	100	114	102	311.1	209	241.3	8	34.9	RF / R39	21	51	-
6" (150)	150	168	159	393.7	282	317.5	12	38.0	RF / R46	52	119	-
8" (200)	200	215	206	482.6	352	393.7	12	44.45	RF / R50	116	283	-
10" (250)	250	265	248	584.2	435	482.6	12	50.8	RF / R54	203	361	-
12" (300)	300	315	305	673.1	520	571.5	16	54.0	RF / R58	373	-	485
14" (350)	350	365	356	749.3	577	635.0	16	60.3	RF / R63	484	-	784
16" (400)	400	418	384	825.5	641	704.8	16	66.6	RF / R67	587	-	906
18" (450)	450	470	468	914.4	704	774.7	16	73.0	RF / R71	790	-	1170
20" (500)	500	520	533	984.2	755	831.8	16	79.3	RF / R75	1275	-	2498
24" (600)	600	620	559	1168.4	901	990.6	16	92.0	RF / R79	2713	-	2643

# DUAL PLATE CHECK VALVE

## ANSI # 2500

**Features** : Retainer Type / Retainer Less  
**Size** : 2" ~ 12"  
**Rating** : ANSI # 2500

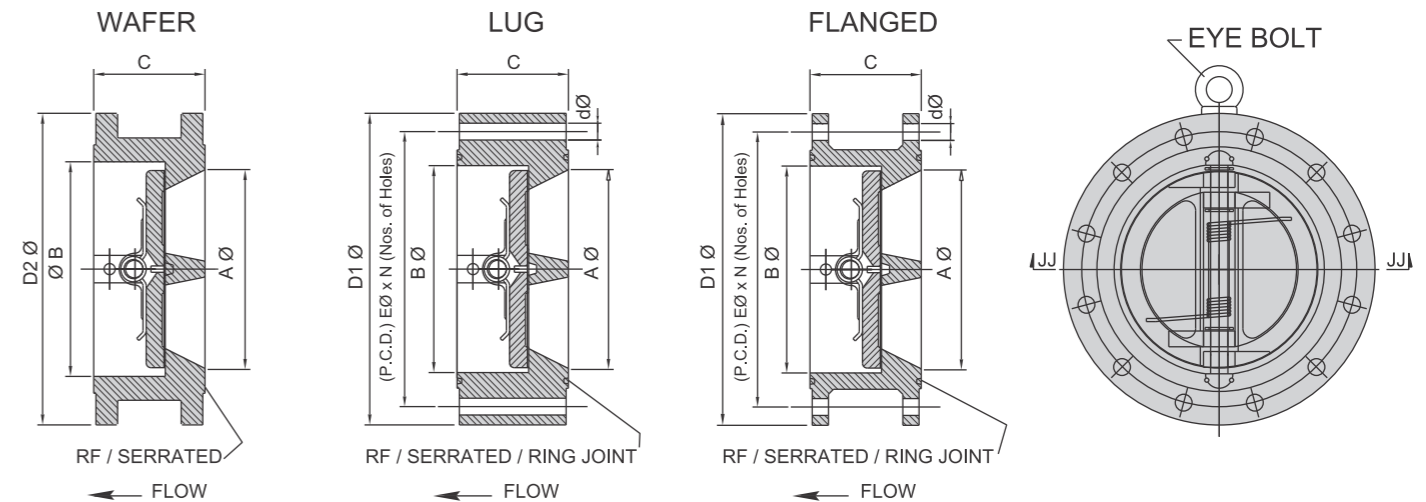

SECTION - JJ

### Installation Dimensions

Size: 2" to 12"

Rating: ANSI #2500

Flange: ANSI B16.5

Size Inches (DN)	Aø mm	Bø mm	C mm	D1ø Lug/Flg. mm	D2ø Wafer mm	Eø P.C.D. mm	N	dø mm	End Facing	Approx Weight In kg.		
										Wafer	Lug	Flanged
2" (50)	50	60	70	235	146	171.4	8	29	RF / R26	13	19	-
3" (80)	76	90	86	305	196	228.6	8	38	RF / R32	16	38	-
4" (100)	100	114	105	356	234	273.0	8	41	RF / R38	29	69	-
6" (150)	150	168	159	483	317	368.3	8	54	RF / R47	70	184	-
8" (200)	200	215	206	553	387	438.1	12	54	RF / R51	132	396	-
10" (250)	250	265	254	673	476	539.7	12	67	RF / R55	216	489	-
12" (300)	300	315	305	762	548	619.1	12	73	RF / R60	394	-	596

# Material Selection Guide

Chemical Agents	Metals					Elastomers					Chemical Agents	Metals					Elastomers							
	Ductile Iron	410 ss	316 ss	Al. Bronze	Hastelloy C	Monel	EPDM	Buna N	Neoprene	Hypalon		Viton	Ductile Iron	410 ss	316 ss	Al. Bronze	Hastelloy C	Monel	EPDM	Buna N	Neoprene	Hypalon	Viton	
Acetaldehyde Acetic Acid 50% 50°C Acetic Acid - Anhydride Acetone Acetylene	U	U	E	U	E	F	G	U	U	U	-	Butyric Acid 5% Calcium Carbonate 60°F Calcium Chlorate 20% Calcium Chloride Calcium Chloride Solution	U	G	E	-	E	-	U	U	U	F	U	
Acrylonitrile Air (Dry) Alcohol - Amy1 Alcohol - Butyl Alcohol - Ethyl	G	G	E	E	-	E	U	U	U	U	U	Calcium Hydroxide 50% 175°F Calcium hypochlorite Calcium Sulphate Carbon Dioxide Carbon Tetrachloride	E	E	E	U	U	E	E	E	E	E	E	E
Alcohol - Methyl Alum - Ammonium Alum - Chrome Alum - Potassium Alumina	U	-	E	E	E	E	E	G	G	G	U	Carbonic Acid Chlorine Gas - dry 70°F Chlorobenzene 90% Chromic Acid 5% 70°F Citric Acid 5% 150°F	U	G	G	-	E	G	-	-	-	-	-	-
A1. Chloride A1. Fluoride A1. Hydroxide A1. Hydroxide Amines	U	U	U	U	-	E	E	E	E	E	E	Coffee (food) Copper Sulphate Cyclohexane Dextrose (food) Diacetone	U	U	E	U	-	-	E	U	E	E	E	E
Ammonia, Anhydrous Ammonia Gas 150°F Ammonia Solutions Ammonium Chloride 50% 180°F Ammonium Hydroxide	F	G	E	U	-	-	E	G	-	-	U	Dichloroethene Diesel Fuels Diethyl Amine Dowtherms Drilline Mud	U	-	F	-	-	-	U	U	U	U	G	
Ammonium Nitrate 5% 60°F Ammonium Phosphate Ammonium Sulphate Amyl Acetate Amylchloride	F	G	E	U	E	G	-	E	E	F	-	Ethers Ethyl Acetate Ethyl Chloride 5% Ethyl Glycol Ethylene Oxide	U	-	E	E	E	G	U	U	U	U	-	
Aniline 90% 70°F Asphalt Barium Carbonate 60°F Barium Chloride Barium Hydroxide	F	G	E	F	E	-	G	U	U	U	G	Fats Ferric Chloride Ferric Nitrate Ferric Sulphate 5% Ferrous Sulphate	E	E	E	E	-	-	U	E	G	G	-	
Barium Sulphate Barium Sulphide Beer (Beverage) Beer Sugar Solution Benzaldehyde	U	-	E	G	-	G	E	E	E	E	E	Fluorine Fluosilicic Acid Formaldehyde 70°F Fromic Acid 5% 150°F Freon	U	U	U	U	-	G	-	G	F	G	-	
Benzene (benzol) 70°F Benzoic Acid 5% Borax Boric Acid 5% 200°F Brine	F	E	E	E	E	G	U	U	U	U	G	Fruit Juices (food) Fuel Oil Gallie Acid 5% 200°F Gasoline Glucose	U	U	E	U	E	-	G	G	G	-	-	
Bromine - Gas Bromine - water Butadiene Butane - Butylene Butyl Acetate	U	U	U	-	E	F	U	U	U	U	G	Glycerine / Glycerol Heptane Hexane Hydrobromic Acid 200°F Hydrochloric Acid 15% 60°F	F	E	E	G	E	G	-	E	E	E	E	

**Code:**  
**E:** Excellent - The fluid has from a null to minimum effect  
**F:** Fair - The fluid has from moderate to severe effect  
**G:** Good - The fluid has from minimum to moderate effect  
**U:** Unsuitable

Chemical Agents	Metals					Elastomers					Chemical Agents	Metals					Elastomers							
	Ductile Iron	410 ss	316 ss	Al. Bronze	Hastelloy C	Monel	EPDM	Buna N	Neoprene	Hypalon		Viton	Ductile Iron	410 ss	316 ss	Al. Bronze	Hastelloy C	Monel	EPDM	Buna N	Neoprene	Hypalon	Viton	
Hydrochloric Acid 37% 60° Hydrofluoric Acid 20% Hydrofluoric Acid 20 - 60% Hydrogen Hydrogen Peroxide 90%	U	U	U	U	E	U	U	U	E	E	E	Propane Resins Sea Water 70°F Soap Solution (strearate) Sodium Acetate 5%	F	E	E	E	-	-	U	E	E	E	E	E
Hydrogen Sulfide Iodine Solution Iso-octane Isopropyl Alcohol Isopropyl Ether	F	F	G	F	-	-	E	U	G	F	U	Sodium Bisulfate Sodium Carbonate Sodium Chloride 30% 180°F Sodium Cyanide Sodium Fluoride 5% 60°F	U	F	E	-	-	-	-	E	E	-	E	E
Kerosene Lactic Acid 5% Lubricating Oil Magnesium Chloride 4% Magnesium Hydroxide	E	E	E	E	E	E	U	E	F	F	E	Sodium Hydroxide 50% 122°F Sodium Hydroxide 50% 176°F Sodium Hypochlorite 5% 60°F Sodium Nitrate Sodium Perborate	U	F	G	U	E	G	E	U	G	E	U	U
Magnesium sulphate Mercuric Chloride 3% Mercury Methane Methyl Acetate	F	G	E	E	E	E	E	E	E	E	E	Sodium Peroxide Sodium Phosphate 5% Sodium Silicate Sodium Sulfide 70% Sodium Sulfite	U	G	E	U	-	-	E	G	G	G	E	E
Methyl Acetone Methyl Chloride Methyl Ethyl Ketone Milk (Food)	F	E	E	E	-	-	G	U	U	U	U	Sodium Sulphate 80% 60°F Steam 300°F Stearic Acid 90% 200°F Sulphur (Molten)	U	G	E	G	E	G	E	E	E	E	E	E
Mineral Oil Molasses (Food) Naphthalene Natural Gas Nickle Chloride	F	-	F	-	E	-	U	E	G	G	E	Sulphur Dioxide Sulphur Trioxide Sulphuric Acid 10% Sulphuric Acid 50% Sulphuric Acid 93% 70°F	U	G	E	F	E	E	G	U	U	F	E	E
Nitric Acid Less 40% 70°F Nitric Acid More 40% 70°F Nitrobenzene Oleum Olive Oil	U	-	-	U	G	U	U	U	U	E	E	Sulphurous Acid 80% 100°F Tannic Acid 10% 150°F Tar Tartaric Acid 150°F Thinner	U	U	U	U	E	U	U	U	-	G	E	E
Oxygen 200°F Oxygen 300°F Palmitic Acid Perchloroethylene Petroleum	E	E	E	E	E	E	E	G	G	G	E	Tributyl Phosphate Trichloroethylene Tricresyl Phosphate Triethanolamine Turpentine	U	F	E	-	-	-	U	U	U	G	F	E
Phenol Phosphoric Acid 5% Phosphoric Acid 85% 70°F Picric Acid 80% Potassium Cyanide	U	-	E	-	E	E	U	U	U	U	E	Vinegar 70°F Water - Demineralized Water - Distilled Water - Fresh Water - Mineral	U	-	E	-	E	-	G	E	G	G	E	E
Potassium Hydroxide 5% Potassium Nitrate Potassium Phosphate Potassium Sulfide Potassium Sulfite	F	G	E	F	E	G	E	E	E	E	E	Water - Sewage Whiskey and Wines Xylene, Xylol Zinc Chloride 5% 160°F Zinc Sulphate 25% 180°F	U	G	E	E	E	E	E	G	-	G	-	-



# Ordering Instruction for Dual Plate Check Valve

Series
Description
Dual Plate Check Valve-Wafer-Retainerless
Dual Plate Check Valve-Lug-Retainerless
Dual Plate Check Valve-Flanged-Retainerless
Dual Plate Check Valve-Hub End-Retainerless

ANSI / API Pressure Rating	
Code	Description
150	Class # 150
300	Class # 300
600	Class # 600
900	Class # 900
1500	Class # 1500
2500	Class # 2500

Plate Material	
Code	Description
WCB	ASTM A216 Gr.WCB
CA 15	ASTM A217 Gr.CA15
CF8	ASTM A351 Gr.CF8
CF8M	ASTM A351 Gr.CF8M
CF3M	ASTM A351 Gr.CF3M
CF8C	ASTM A351 Gr.CF8C
AB	ASTM B148
DPX	ASTM A890 Gr.4A
SDPX	ASTM A890 Gr.6A

Spring	
Code	Description
SS 316	AISI 316
Inconel	INCONEL X750



Size In Inches
Code
2 ~ 48
2 ~ 10
12 ~ 48
2 ~ 20

Body Material	
Code	Description
WCB	ASTM A216 Gr.WCB
LCB	ASTM A216 Gr.LCB
LCC	ASTM A216 Gr.LCC
CA 15	ASTM A217 Gr.CA15
CF8	ASTM A351 Gr.CF8
CF8M	ASTM A351 Gr.CF8M
CF3M	ASTM A351 Gr.CF3M
CF8C	ASTM A351 Gr.CF8C
AB	ASTM B148
DPX	ASTM A890 Gr.4A
SDPX	ASTM A890 Gr.6A

Body Seat	
Code	Description
MM	WCB, As Body Material
MM	CF8M, As Body Material
MM	13% Cr. Overlay
MM	SS 316 Overlay
MM	Stellite - 6
Viton	Viton
Buna-N	Buna-N
Neo	Neoprene
EPDM	EPDM

End Facing	
Code	Description
SF	Smooth Face 125-250 AARH
RF	Raised Face 250-500 AARH
RTJ	Ring Type Joint

**Notes**

**Example : 12-150-WCB/CF8M/MM/INCONEL/RF**

1. For Dimensions refer respective series
2. Please specify any other Testing/Material certification required
3. Certification: As per EN-3.1 B

The Company reserves the right to change product design and specifications without notice

## HUB END CHECK VALVE

**ANSI # 600, # 900, # 1500, # 2500**



### Applications

- Onshore, Offshore & subsea pipeline application
- Oil and Gas Production
- Petrochemical
- Industrial Piping
- Power Generation

**Size Range:** 2" ~ 20"

**Rating:** ANSI #600, #900, #1500, #2500

**Seat:** Metal to Metal

### Features

- Up to 75% lighter and significantly smaller than a comparable ANSI or API flanges
- Close piping and hook-up arrangements with typically 25% smaller Clamp diameter
- Typically 40% shorter connection lengths
- Easier fabrication and installation with no bolt holes to align
- Only 4 bolts to tighten rather than up to 24 on a conventional flange
- The clamp can be rotated completely round the hub for easy bolt Orientation and tightening
- Quicker and easier assembly and disassembly, minimizing Maintenance downtime
- Dimension on request
- Users to specify make of clamp e.g. Graylok, Techlok, Clamplok
- All valves are rated in accordance with ANSI B16.34, API 594, API 598 Design
- DCHR valves have reduced bore internals, usually one size down

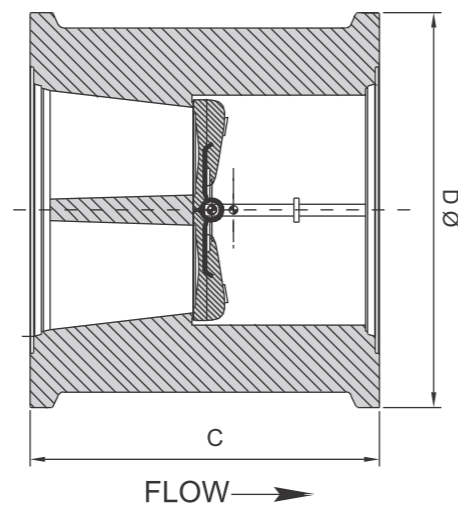
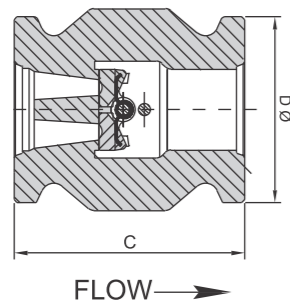





**Jayant Engineering & Marketing Pvt. Ltd.**

Regd. Office & Works: Plot No. 2003/2004, Phase II, G.I.D.C. Chhatral, Ta. Kalol, Dist. Gandhinagar, Gujarat 382729, India.

Ph.: +91 2764 234053, 232182, Fax: +91 2764 233169, Email: sales@jayantvalves.com

[www.jayantvalves.com](http://www.jayantvalves.com)