

AN ISO 9001:2015 COMPANY



BUTTERFLY VALVES



ISO 9001
BUREAU VERITAS
Certification



Advantages of butterfly valve

Butterfly valve is much smaller than other valve designs. The results are saving in materials, less weight, small space requirement, and easy installation and operation. The liner materials used in the construction of Jayant Valves butterfly valve are either Elastomer or TEFLON®. Wafer construction provides maximum strength under conditions of pipeline strain. Jayant Valves perform three basic functions of stopping flows, controlling flow and regulating flows and pressure with several advantage functions such as;

- Tight shut off
- Less fluid resistance achieved through smooth flow
- Low pressure drop
- On-off or throttling applications
- Suitable for automation with low operating torque and 90 degree operating angle
- Reduced weight and installation space
- No flange gasket
- Quick fitting and dismantling
- Easy replacement and renewable seat

Valve configurations scale drawing to actual size

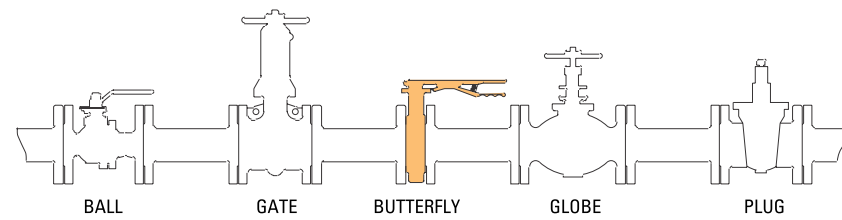

Application

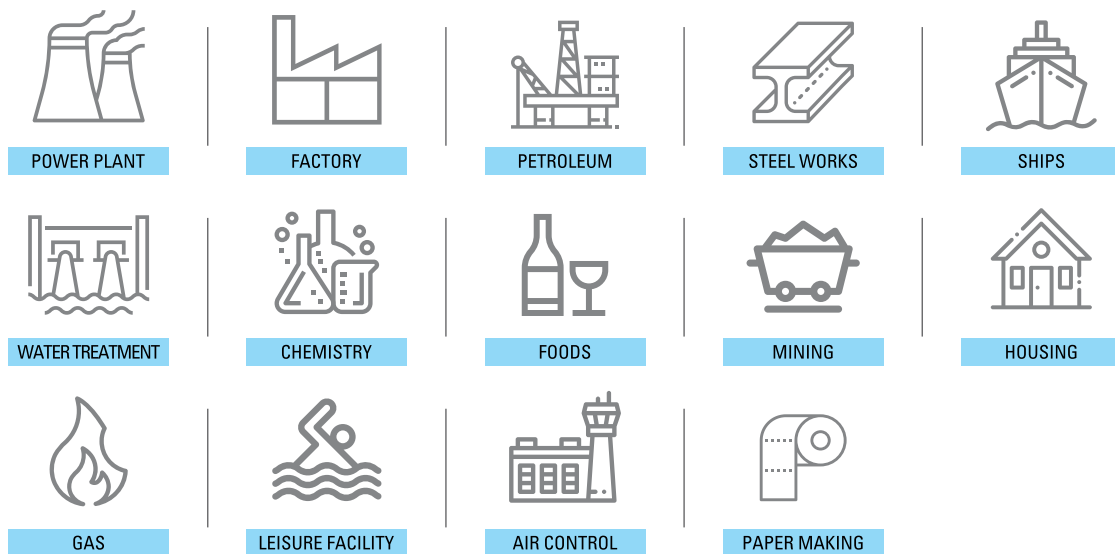

This catalog remains the property of m/s Jayant Engineering & Marketing Pvt. Ltd. Alternation of dimensions, materials, weight and others are reserved and subject to modification without pre-notice

Index

Contents

Concentric rubber lined butterfly valve	04
2 piece split body PTFE lined butterfly valve	12
Double eccentric High Performance butterfly valve	14
Triple eccentric High Performance butterfly valve	17
Engineering data	20

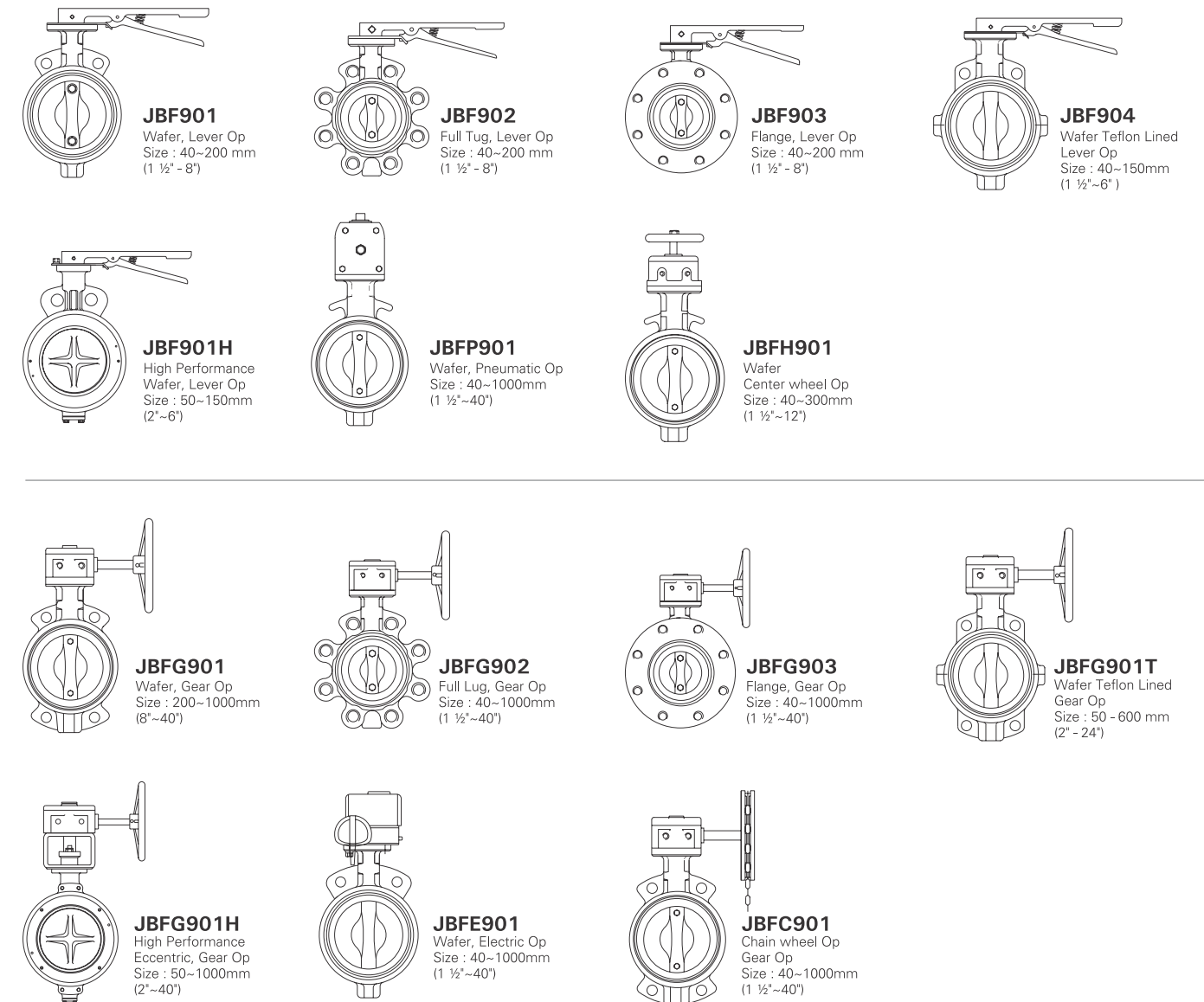

Leak-tightness at Line stream, shaft passages and the atmosphere

A perfect zero leakage seal at bi-direction is obtained by the compression of the inner between the valve body and the edge of the disc. A perfect zero leakage seal is provided by means of flatted liner area around both up and down shaft passages and the spherically machined disc. Since the seat stem hole is smaller than the stem diameter, there is a compression fit forming a secondary seal. The seal insures that no fluid will leak to atmosphere.

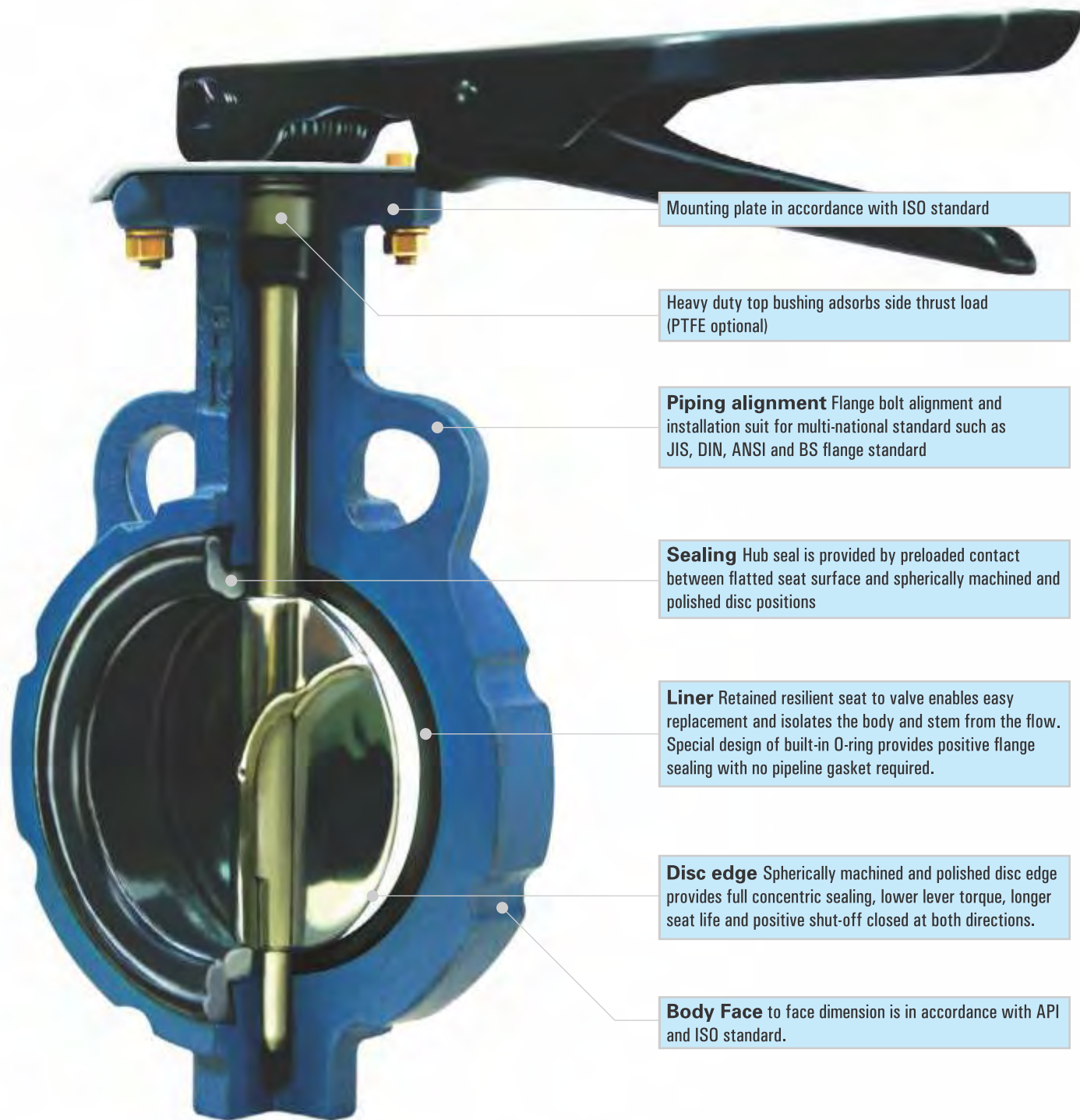

Mounting plate in accordance with ISO standard

Heavy duty top bushing adsorbs side thrust load (PTFE optional)

Piping alignment Flange bolt alignment and installation suit for multi-national standard such as JIS, DIN, ANSI and BS flange standard

Sealing Hub seal is provided by preloaded contact between flatted seat surface and spherically machined and polished disc positions

Liner Retained resilient seat to valve enables easy replacement and isolates the body and stem from the flow. Special design of built-in O-ring provides positive flange sealing with no pipeline gasket required.

Disc edge Spherically machined and polished disc edge provides full concentric sealing, lower lever torque, longer seat life and positive shut-off closed at both directions.

Body Face to face dimension is in accordance with API and ISO standard.

Specifications

Standard

According to ISO 5752 - BS 5155 - MSS SP 67 - API 609

Product range

40mm up to 1000mm (I V ~ 40")

Pressure range

Designed for maximum working pressure of 16bar (240psi)

Flange connections

The shape of valve body has been so designed as to allow flange bolt alignment onto following standards. Wafer type valve has been successfully developed to fit multi functional application onto either connection standard in the same configuration, mainly

ISO PN 6,10,16,20
ANSI B 16.1 CL
BS4504 PN6, PN10, Pn16
AS 2109 Table D and E
MSS SP44 CL. 150
ANSI B 16.5 CL 150
BS 10 Table D and E
JISB2210 5K, 10K, 16K and 20K

Operating

Hand Lever with notch plate
Manual worm gear
With locking device
Electric/Pneumatic actuator
Hydraulic actuator
Chain wheel gear box

Testing

API598
MSS SP 61. ANSI 8 16.104



Materials

Body	• Cast iron	ASTM A 126 Cl. B
	• Ductile iron	ASTM A 536 Gr 65-45-12
	• Carbon steel	ASTM A216 WCB
	• Stainless steel	ASTM A 351 GrCF8-CF8M
	• Bronze	ASTM B 62
Disc	• Ductile iron	ASTM A 536 Gr 65-15-12
	• Stainless steel	ASTM A 351 Gr CF8-CF8M
	• Aluminum bronze	ASTM B 148 Cl.C95500
	• Coated	EPDM, Viton, Buna-N, etc
	• Stainless steel	17-4PH ASTM A 564 TYPE
Stem	• Stainless steel	ASTM A 276 304
	• Stainless steel	ASTM A 276 410
	• Stainless steel	ASTM A 276 316
	• Stainless steel	17-4PH ASTM A 564 TYPE
	• Stainless steel	17-4PH ASTM A 564 TYPE
630	• K-Monel	ASTM B 164
	• Elastomer	Working temperature
	• EPDM	0°C ~ + 80°C
	• NBR	0°C ~ + 70°C
	• Viton	-20°C ~ + 150°C
Seat	• Silicon	-20°C ~ + 120°C
	• Neoprene	-10°C ~ + 70°C
	• EPDM	
	• NBR	
	• Viton	
Packing	• EPDM	
	• NBR	
	• Viton	

WAFER BODY

PN10/PN16/150#

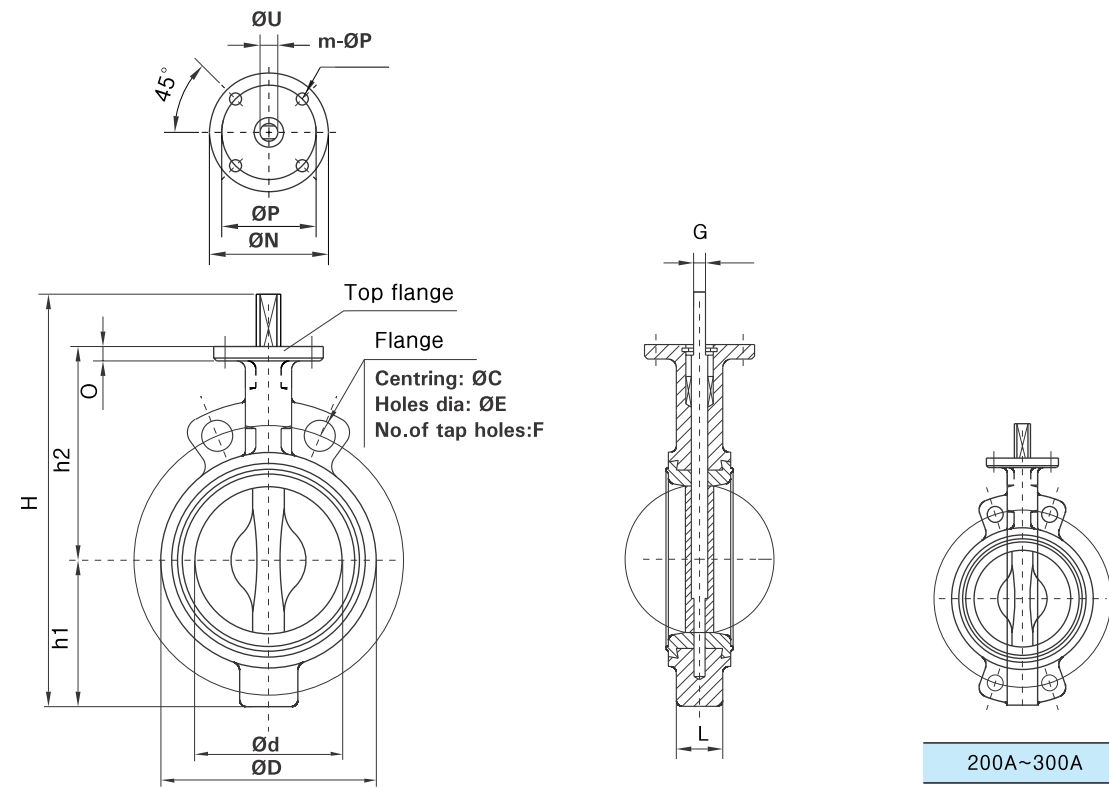

200A~300A

Valve dimensions

Unit(mm)

Size		ØD	Ød	L	H	h1	h2	Stem		Top flange to ISO 5211					Ø	WT (kg)
Inch	mm							ØU	G	Type	ØN	ØP	m	Øs		
1½"	40	86	40	41	205	58	124	10	8	F07	90	70	4	9	10	3.1
2"	50	105	52	43	227	66.5	130.5	14	10	F07	90	70	4	9	11	3.7
2½"	65	114	65	46	241	71	140	14	10	F07	90	70	4	9	11	4
3"	80	129	80	46	263	83	150	14	10	F07	90	70	4	9	11	4.4
4"	100	155	100	52	290	95	163	16	12	F07	90	70	4	9	11	5.9
5"	125	180	125	56	319	110	178	19	15	F07	90	70	4	9	12	8.9
6"	150	207	150	56	347	124	191	19	15	F07	90	70	4	9	12	9
8"	200	260	198	60	433	163	238	22	18	F07	90	70	4	9	13	11
10"	250	331	248	68	546	227	285	28	20	F10	125	102	4	12	15	20
12"	300	377	298	78	601	252	315	28	20	F10	125	102	4	12	15	31.5

refer to flange drilling on page 24

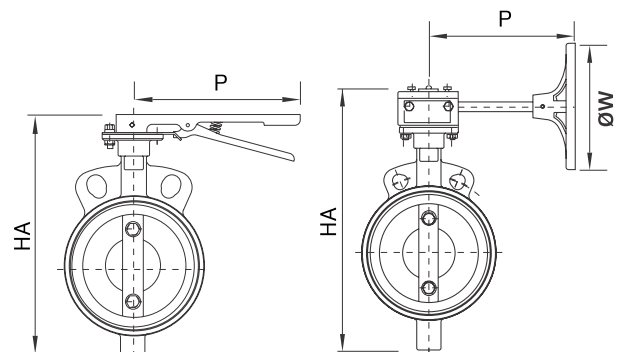

Dimensions

Unit(mm)

Size	Inch	2"	2.5"	3"	4"	5"	6"	8"	10"	12"
	mm	50	65	80	100	125	150	200	250	300
LEVER	HA	228	246	268	292	327	358.5	445		
	P	210	210	210	262	262	262	297		
GEAR 568	HA	254	264	280		316	351	382.5	469	
	P	150	150	150	150		150	150	225	

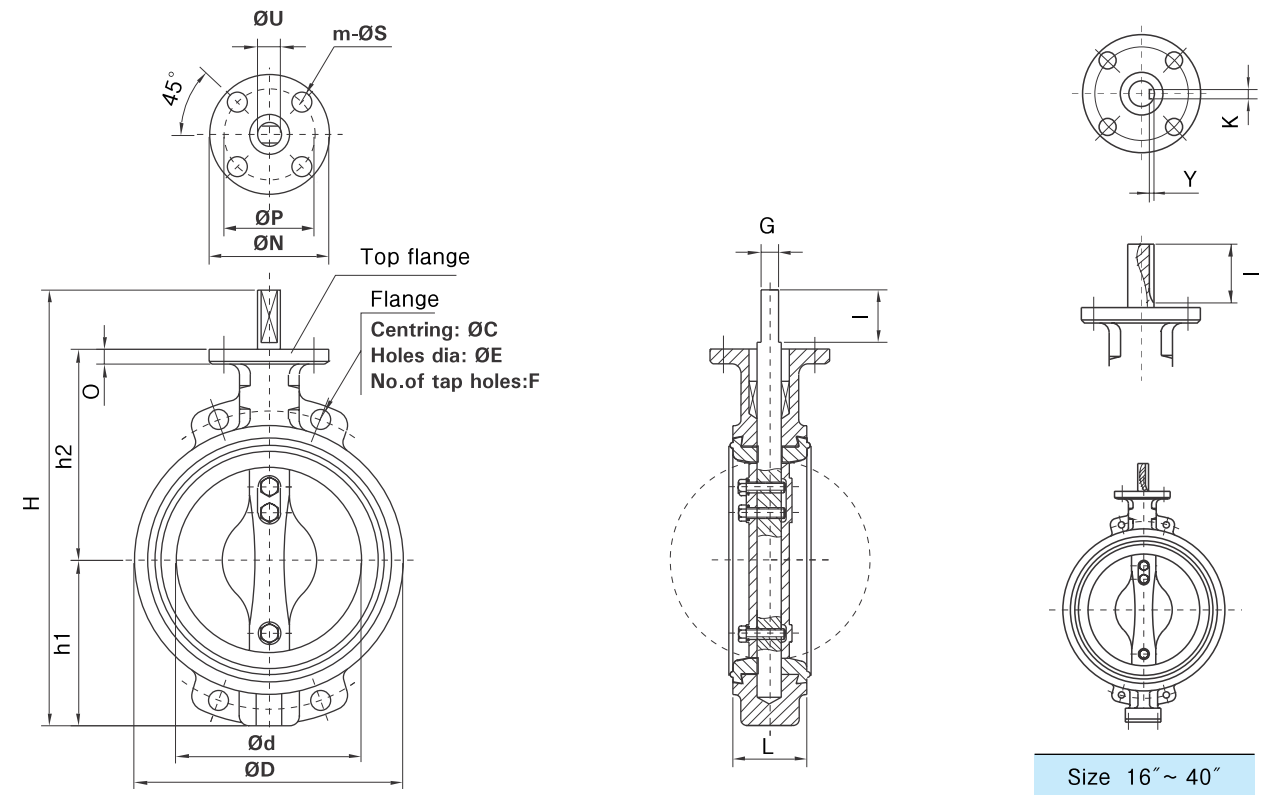

Size 16~40"

Valve dimensions

Unit(mm)

Size		ØD	Ød	L	H	h1	h2	Stem					Top flange to ISO 5211					Ø	WT (kg)
Inch	mm							ØU	G	I	Y	K	Type	ØN	ØP	m	Øs		
14"	350	416	327	78	675	271	324	32	19.5	45	-	-	F10	125	102	4	12	20	43
16"	400	475	387	102	817	343	369	35	-	60	5	10	F14	175	140	4	18	23	63.5
18"	450	535	438	114	877	366	406	38	-	60	5	10	F14	175	140	4	18	23	99
20"	500	590	477	127	1008	421	485	45	-	60	5	10	F16	230	190	5	19	34	114.5
24"	600	695	560	154	1180	493	570	50	-	60	5	10	F16	230	190	5	19	34	214.5
28"	700	800	690	165	1355	580	574	70	-	120	5	10	F25	230	190	5	18.5	35	377
30"	750	857	729	180	1445	656	615	70	-	120	5	10	F25	300	250	5	22	35	460
32"	800	920	785	180	1495	630	669	80	-	140	5.5	14	F25	300	250	5	22	35	542
36"	900	1020	900	180	1625	690	671	80	-	140	5.5	14	F30	300	250	5	22	38	699
40"	1000	1125	990	200	1802	790	842	90	-	140	5.5	14	F30	300	250	5	22	40	977

refer to flange drilling on page 24

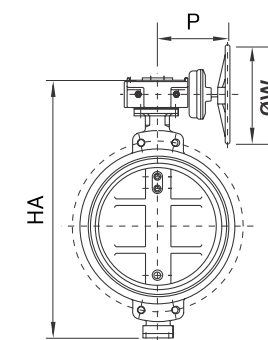

Dimensions

Unit(mm)

Size	Inch	14"	16"	18"	20"	22"	24"	28"	30"	32"	36"	40"
	mm	350	400	450	500	550	600	700	750	800	900	1000
GEAR 1775	HA	657	807	867	1013	1059	1172	1310	1355	1455	1510	
	P	270	330	330	330	330	330	320	320	320	330	330
	W	300	400	400	400	400		400	700	700	700	

FULL LUG BODY

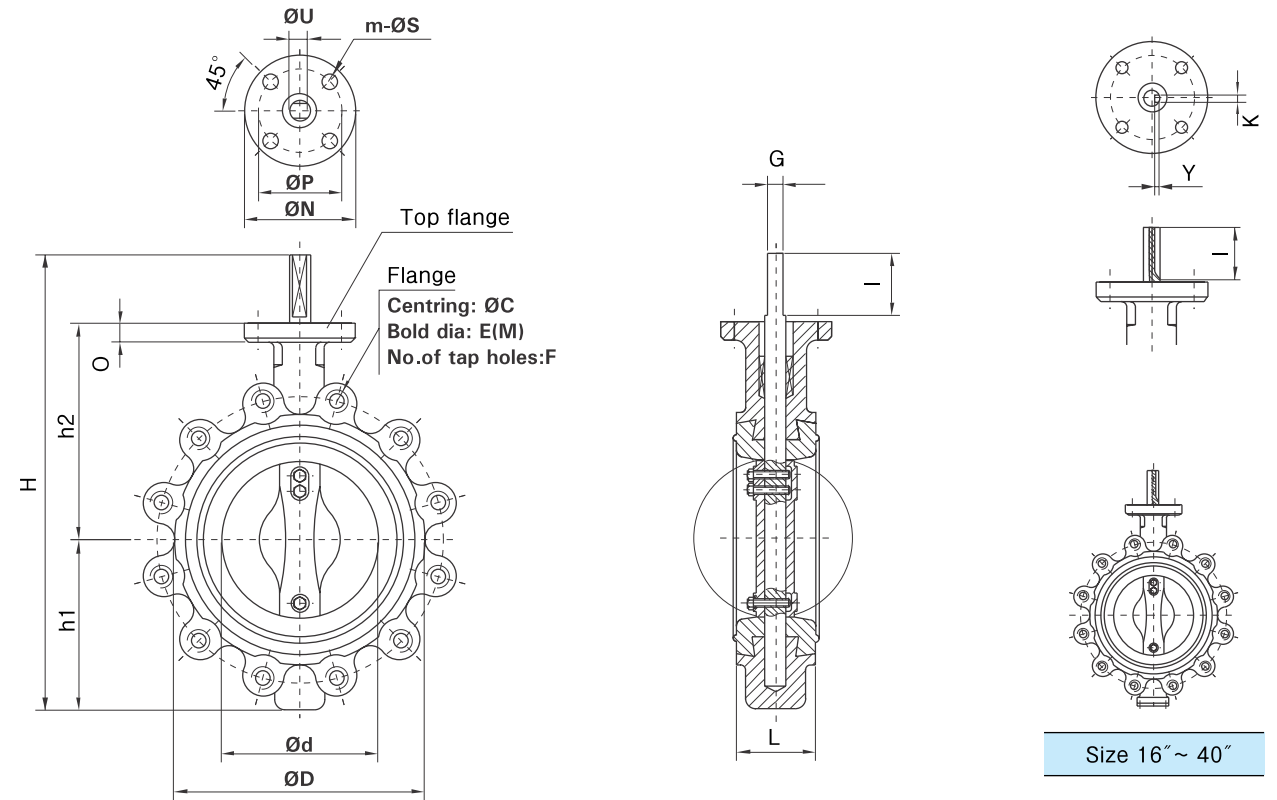
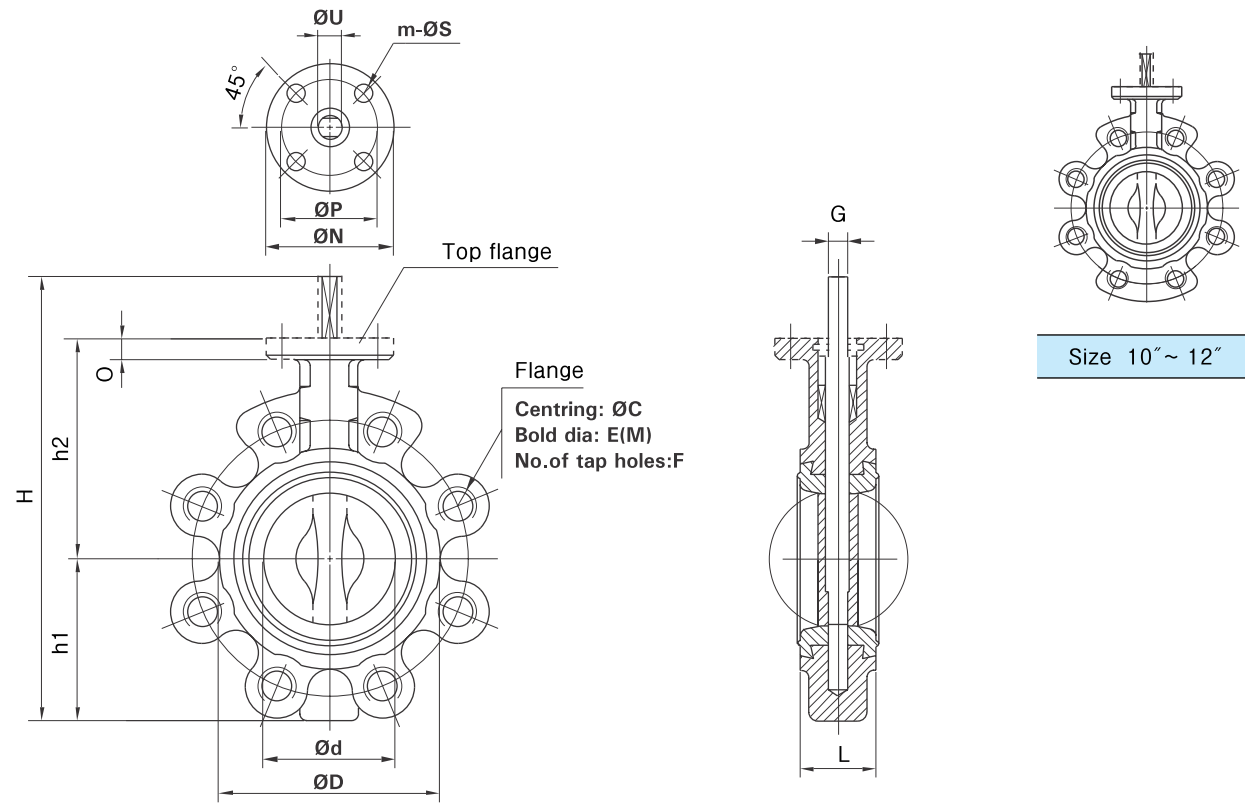

Valve dimensions

Size		Unit(mm)														
Inch	mm	ØD	Ød	L	H	h1	h2	Stem		Top flange to ISO 5211					Ø	WT (kg)
								ØU	G	Type	ØN	ØP	m	Øs		
1½"	40	86	40	41	205	58	124	10	8	F07	90	70	4	9	10	3.5
2"	50	100	52	43	235	72.5	130.5	14	10	F07	90	70	4	9	11	4.1
2½"	65	112	65	46	237	75.5	129.5	14	10	F07	90	70	4	9	11	5.5
3"	80	126	80	46	255	82	143	14	10	F07	90	70	4	9	11	6.8
4"	100	153	100	52	292	99.5	160.5	16	12	F07	90	70	4	9	11	8.6
5"	125	182	125	56	317	111	177	19	15	F07	90	70	4	9	12	10.5
6"	150	210	150	56	357	134	191	19	15	F07	90	70	4	9	12	12.5
8"	200	255	198	60	412	163	217	22	18	F07	90	70	4	9	13	21.4
10"	250	328	248	68	519	218	267	28	20	F10	125	102	4	12	15	29.3
12"	300	374	298	78	588	249	295	28	20	F10	125	102	4	12	15	44

refer to flange drilling on page 24

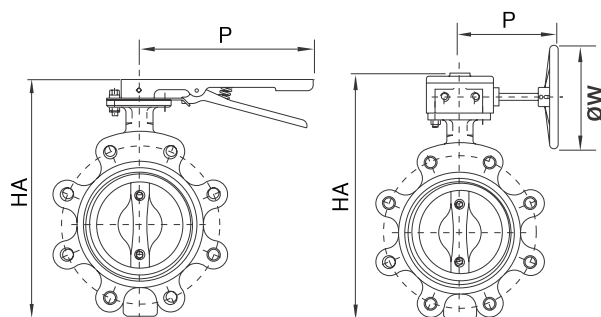

Dimensions

Size		Unit(mm)									
Inch	mm	2"	2.5"	3"	4"	5"	6"	8"	10"	12"	
		50	65	80	100	125	150	200	250	300	
LEVER	HA	233	245	262	292	318	359	431			
	P	227	227	227	282		285	285	285		
GEAR	HA	257	265	280		314	359	397	452	553	
	P	130	130	130	130		160	160	210	210	

Valve dimensions

Size		Unit(mm)																	
Inch	mm	ØD	Ød	L	H	h1	h2	Stem					Top flange to ISO 5211					Ø	WT (kg)
								ØU	G	I	Y	K	Type	ØN	ØP	m	Øs		
14"	350	416	327	78	675	271	324	32	19.5	45	-	-	F10	125	102	4	12	20	2.2
16"	400	475	387	102	817	343	369	35	-	60	5	10	F14	175	140	4	18	23	112
18"	450	535	438	114	877	366	406	38	-	60	5	10	F14	175	140	4	18	23	153
20"	500	586	477	127	1008	421	485	45	-	60	5	10	F16	230	190	5	19	34	199
24"	600	695	560	154	1180	493	570	50	-	60	5	10	F16	230	190	5	19	34	283
28"	700	800	690	165	1355	580	574	70	-	120	5	10	F25	230	190	5	18.5	35	490
30"	750	857	729	180	1445	656	615	70	-	120	5	10	F25	300	250	5	22	35	598
32"	800	920	785	180	1495	630	669	80	-	140	5.5	14	F25	300	250	5	22	35	677
36"	900	1020	900	180	1625	690	671	80	-	140	5.5	14	F30	300	250	5	22	38	874

refer to flange drilling on page 24

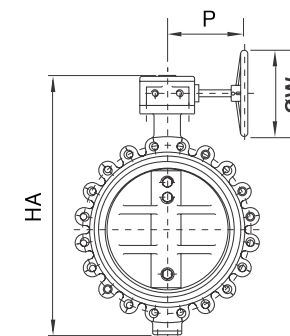

Dimensions

Size		Unit(mm)										
Inch	mm	14"	16"	18"	20"	22"	24"	28"	30"	32"	36"	40"
		350	400	450	500	550	600	700	750	800	900	1000
GEAR	HA	657	807	867	1013	1059	1172	1310	1355	1455	1510	
	P	270	330	330	330	330	330	320	320	320	330	330
1775	W	300	400	400	400	400		400	700	700	700	

DOUBLE FLANGE BODY

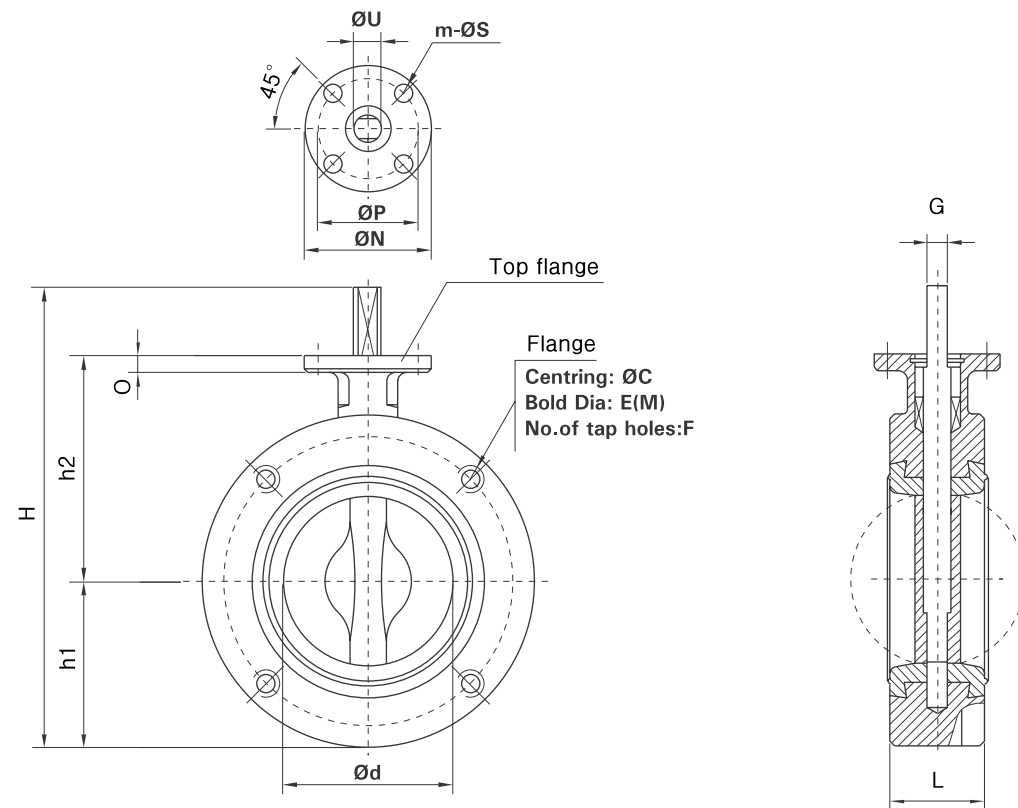

Valve dimensions

Size		Ød	L	H	h1	h2	Stem		Top flange to ISO 5211					Ø	WT (kg)
Inch	mm						ØU	G	Type	ØN	ØP	m	Øs		
1½"	40	40	41	205	58	124	10	8	F07	90	70	4	9	10	6.2
2"	50	52	43	240	77.5	130.5	14	10	F07	90	70	4	9	11	6.8
2½"	65	65	46	247	87.5	129.5	14	10	F07	90	70	4	9	11	8.9
3"	80	80	46	266	92.5	143	14	10	F07	90	70	4	9	11	10.2
4"	100	100	52	298	105	160.5	16	12	F07	90	70	4	9	11	14.5
5"	125	125	56	331	125	177	19	15	F07	90	70	4	9	12	16.8
6"	150	150	56	357	134	191	19	15	F07	90	70	4	9	12	12.5
8"	200	198	60	412	163	217	22	18	F07	90	70	4	9	13	31.2
10"	250	248	68	506	205	267	28	20	F10	125	102	4	12	15	46.2
12"	300	298	78	538	248.5	295	28	20	F10	125	102	4	12	15	58.8

refer to flange drilling on page 24

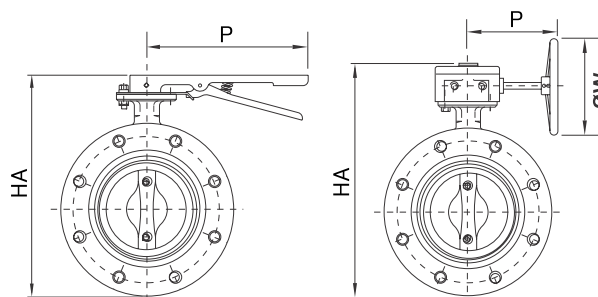

Dimensions

Size	Inch	2"	2.5"	3"	4"	5"	6"	8"	10"	12"
	mm	50	65	80	100	125	150	200	250	300
LEVER	HA	238.5	257.5	272.5	298	333	365	433		
	P	227	227	227	285		285	285	285	
GEAR	HA	262.5	277.5	290.5		320	374	403	454	558
602.5	P	130	130	130	130		160	160	210	220

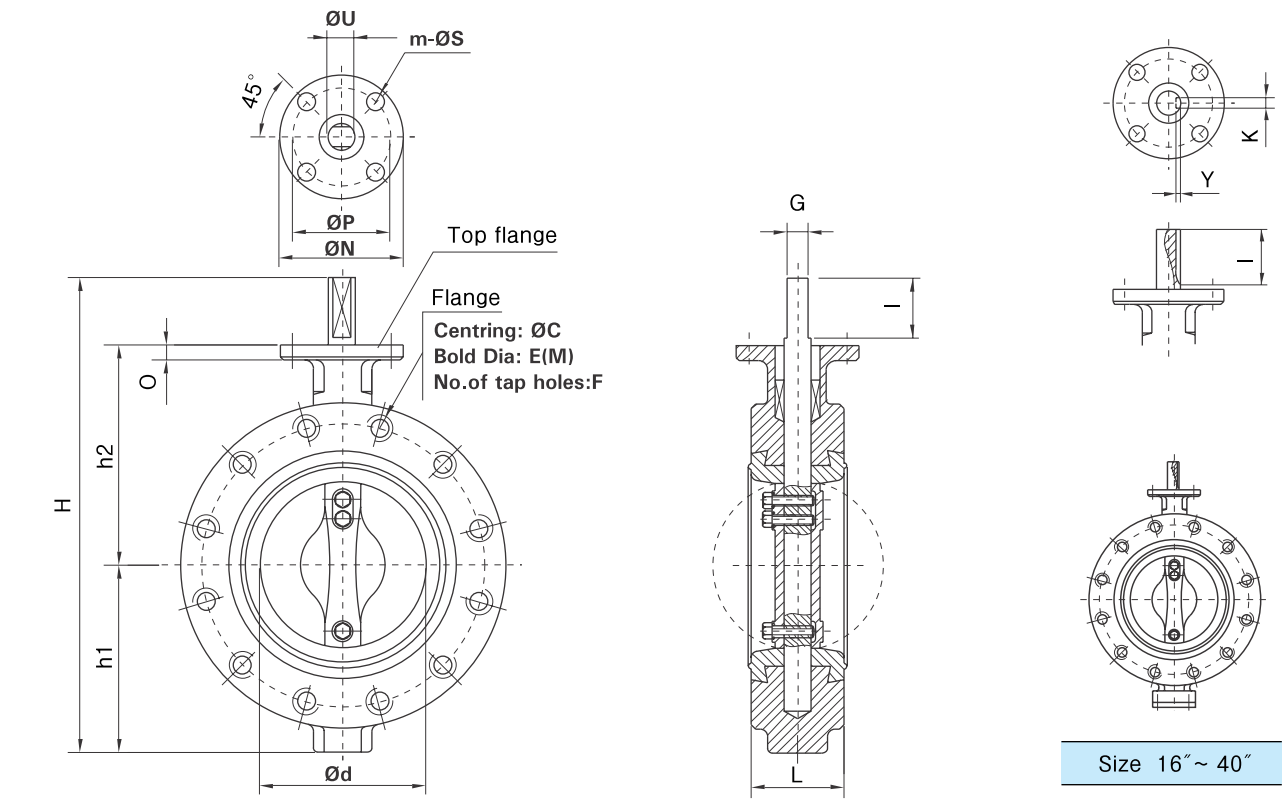

Valve dimensions

Size		Ød	L	H	h1	h2	Stem					Top flange to ISO 5211					Ø	WT (kg)
Inch	mm						ØU	G	I	Y	K	Type	ØN	ØP	m	Øs		
14"	350	327	78	675	271	324	32	19.5	45	-	-	F10	125	102	4	12	20	66.6
16"	400	387	102	817	343	369	35	-	60	5	10	F14	175	140	4	18	23	96
18"	450	438	114	877	366	406	38	-	60	5	10	F14	175	140	4	18	23	147
20"	500	477	127	1008	421	485	45	-	60	5	10	F16	230	190	5	19	34	161
24"	600	560	154	1180	493	570	50	-	60	5	10	F16	230	190	5	19	34	292
28"	700	690	165	1355	580	574	70	-	120	5	10	F25	230	190	5	18.5	35	539
30"	750	729	180	1445	656	615	70	-	120	5	10	F25	300	250	5	22	35	658
32"	800	785	180	1495	630	669	80	-	140	5.5	14	F25	300	250	5	22	35	745
36"	900	900	180	1625	690	671	80	-	140	5.5	14	F30	300	250	5	22	38	944

refer to flange drilling on page 24

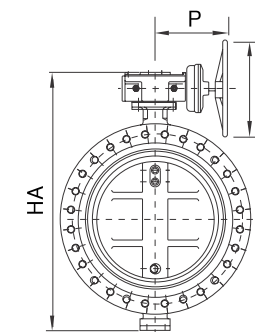

Dimensions

Size	Inch	14"	16"	18"	20"	22"	24"	28"	30"	32"	36"	40"
	mm	350	400	450	500	550	600	700	750	800	900	1000
GEAR	HA	657	807	867	1013	1059	1172	1310	1355	1455	1510	
1775	P	270	330	330	330	330	330	320	320	320	330	330
	W	300	400	400	400	400		400	400	400	400	

TWO PIECE SPLIT BODY TEFLON® LINED

Teflon® covered one-piece stainless steel disc and shaft

The seat configuration of the resiliency of elastomer back-up ring and the chemical resistance of a Teflon® makes valve with more suitable for application such as toxic and corrosive media where elastomers are unsuitable.

One-piece disc/shaft provide the minimum obstruction to fluid flow since shaft-attachment obstruction is eliminated. This results in excellent flow characteristics and makes a valve suited for the processing industries because fluid contact is limited to the seat and disc only

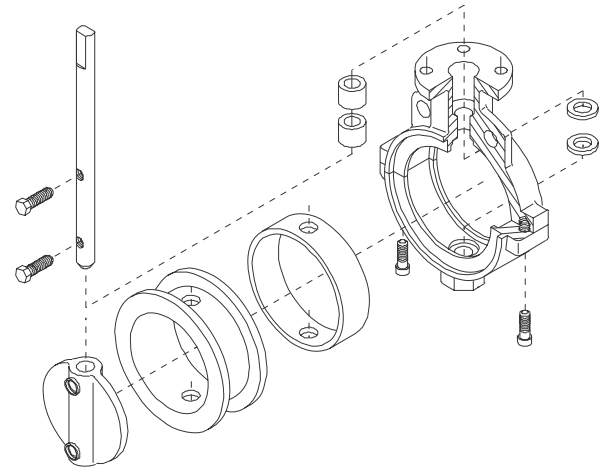

Application

Chemicals, acids, corrosive products

General Characteristics

Two piece-body
Bi-directional
Centred butterfly
1 piece stem and butterfly

Construction

Body cast steel / stainless steel
Stainless steel butterfly PTFE lined
PTFF sleeve with rubber backup pad

Coating

Painting: oven backed epoxy powder coating, 150u

Working Conditions

5.5 Bar pressure

Hydraulic Tests

1.1 times the maximum working pressure

Connection

Between flanges ISO PN 10/16, ANSI B 16.5.150

Handling Possibilities

Lever
Gear box with opening indicator
Single or double effect pneumatic actuator
Electric motors 220/380 V mono/tri

One-piece stainless steel disc/shaft

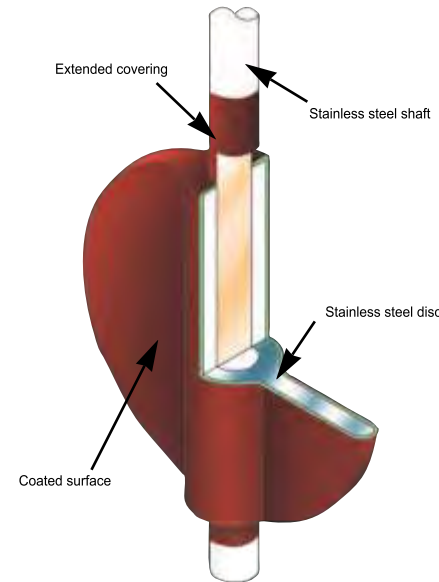

Cut away PFA coated Disc-Stem

Stainless steel with finish allows proper secondary seal and bearing conditions at seat hole

Extended covering from primary seal through secondary seal into seat hole area assures stem isolation

Complete encapsulation affords complete isolation of steel disc

PFA covered disc suitable not only for chemically resistant but for handling abrasives in the processing industries

Material standard

Body Cast iron, WCB, Ductile iron, Stainless Steel and As per Customer requirements

Disc Hard rubber lined steel, SS 304-3016 and As per Customer requirements

Seat All kind of rubber, PTFE and As per Customer requirements

TWO PIECE BODY TEFLON® LINED

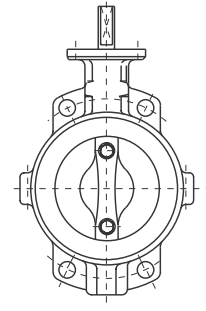
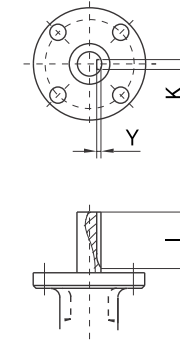
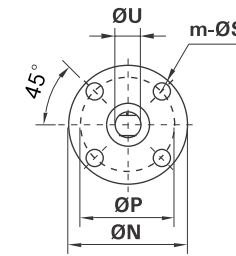

Size 8"

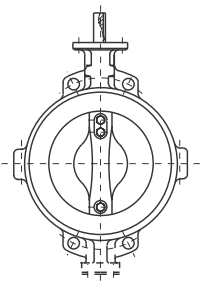
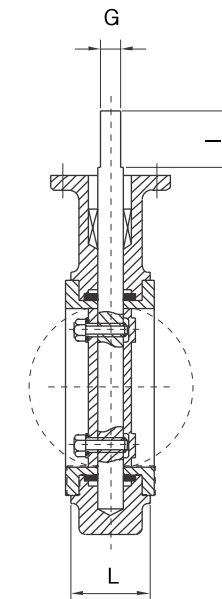
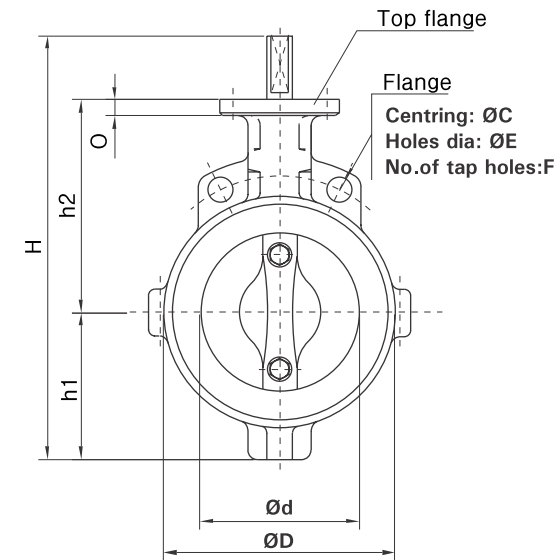

Size 16"~24"

Valve dimensions

Size		ØD	Ød	L	H	h1	h2	Stem					Top flange to ISO 5211				WT (kg)		
Inch	mm							ØU	G	I	Y	K	Type	ØN	ØP	m		Øs	0
2"	50	102	52	43	227	66.5	130.5	14	10	38	-	-	F07	90	70	4	9	11	4.3
2½"	65	115	65	46	241	71	140	14	10	38	-	-	F07	90	70	4	9	11	4.5
3"	80	128	80	46	263	83	150	14	10	38	-	-	F07	90	70	4	9	11	4.9
4"	100	153	100	52	290	95	163	16	12	38	-	-	F07	90	70	4	9	11	6.3
5"	125	183	125	56	319	110	178	19	15	38	-	-	F07	90	70	4	9	12	8.9
6"	150	210	150	56	347	124	191	19	15	38	-	-	F07	90	70	4	9	12	9.4
8"	200	259	198	60	433	163	238	22	18	38	-	-	F07	90	70	4	9	13	11.5
10"	250	328	248	68	546	227	285	28	20	45	-	-	F10	125	102	4	12	15	21
12"	300	374	298	78	601	252	315	28	20	45	-	-	F10	125	102	4	12	15	32
14"	350	416	327	78	675	271	324	32	19.5	45	-	-	F10	125	102	4	12	20	43.6
16"	400	475	387	102	817	343	369	35	-	60	5	10	F14	175	140	4	18	23	64
18"	450	535	438	114	877	366	406	38	-	60	5	10	F14	175	140	4	18	23	99.7
20"	500	586	477	127	1008	421	485	45	-	60	5	10	F16	230	190	5	19	34	115

Unit(mm)

DOUBLE ECCENTRIC HIGH PERFORMANCE

Specifications

Product range

40mm upto 1000mm (1½" ~ 40")

Pressure Temperature range

Metal seat type WMP 4.90Mpa (50kgf/cm²) WMT 450 deg. Cels.

Teflon seat type WMP 1.96Mpa (20kgf/cm²) WMT 230 deg. Cels.

Flange connections

ISO PN 10, 16, 20 and 25 MSS SP 44 CL. 150, 300
ANSI B 16.1 CL ANSI B 16.5 CL. 150, 300
BS 4504, PN 10, PN 16 BS10 Table D and E
As2129 Table D and E JIS B 221010K, 16K and 20K

Test and Inspection Conforms to API 598

Body test 1.5 times the maximum working pressure with water. The test is performed on the assembled valve with the disc in half open position

Seat and shaft seal test 1.1 times the maximum working



Seat Construction

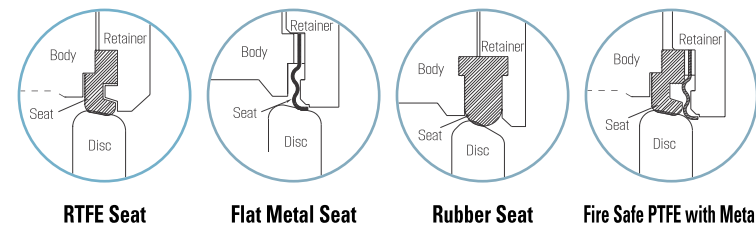

Fire-safe seat

After a fire when the R-PTFE seat has burned away, the supplementary metal sealing seat will be activated automatically and prevent from excessive flow.

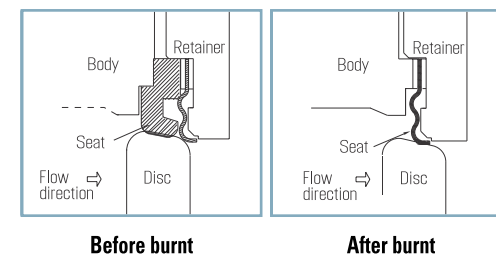

Materials

Body	Ductile iron	ASTM A 536 Gr 65-45-12
	Carbon steel	ASTM A216WCB
	Stainless steel	ASTM A 351 Gr CF8-CF8M
	Aluminum bronze	ASTM B 148 C95500
Disc	Stainless steel	ASTM A 351 Gr CF8-8M
	Aluminum bronze	ASTM B 148 C95500
Stem	Stainless steel	ASTM A 276 304
	Stainless steel	ASTM A 276 410
	Stainless steel	ASTM A 276 316
	Stainless steel	17-4PH ASTM A 564 TYPE
	630	K-Monel
Seat	Elastomer	
	Teflon	
	Metal	

Features

- Double eccentric disc and stem
- Spherical sealing structure
- Low operating torque
- Low friction and wear
- Renewable cartridge seat

Application

- Chemical processing
- Power plant
- Hydrocarbon processing
- Shipbuilding

WAFER BODY (SEMI LUG)

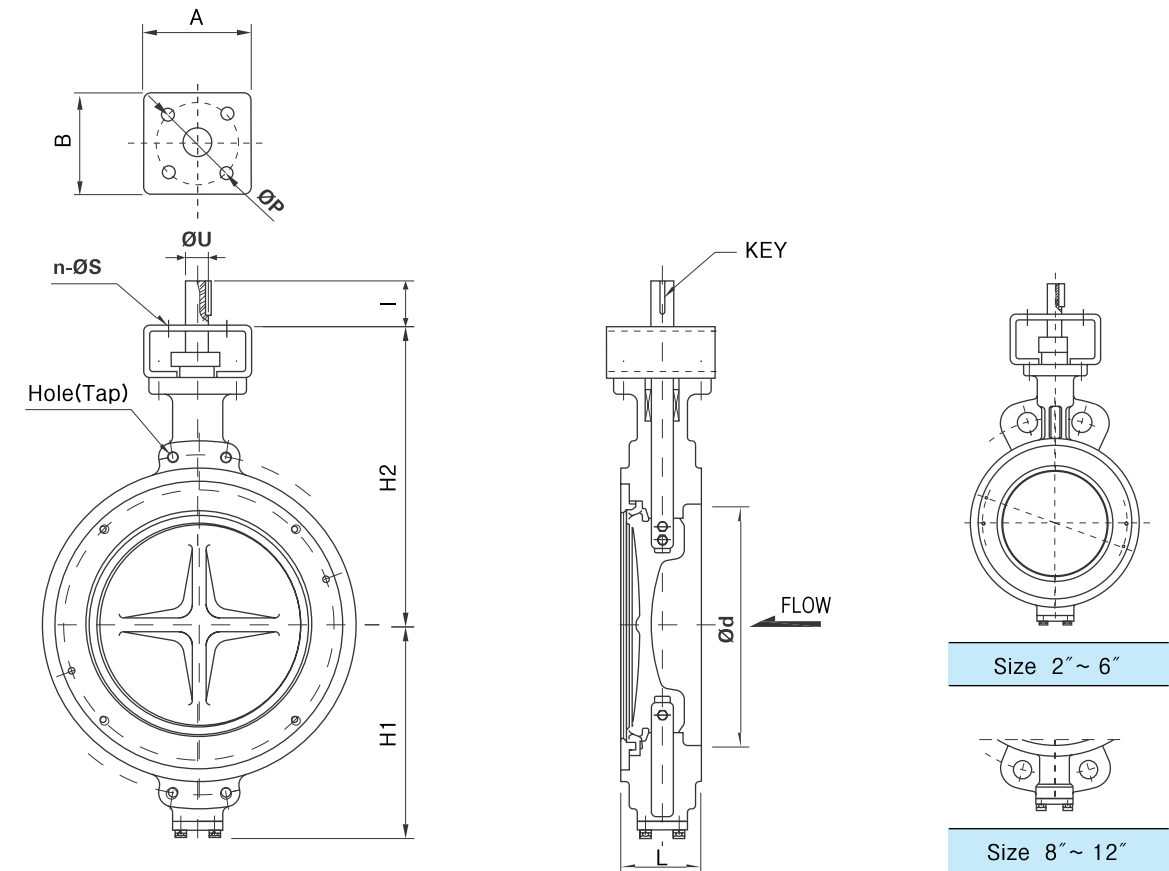

Valve dimensions

Size	Unit(mm)														
	Inch	mm	Ød	L	H1	H2	I	ØU	Key	Type	Top flange to ISO 5211				
2"	50	55	60	62	182	40	14	5X5X29	F07	82	70	70	4	10	
2½"	65	70	48	72	192	40	14	5X5X29	F07	82	70	70	4	10	
3"	80	84	48	82	202	40	14	5X5X29	F07	82	70	70	4	10	
4"	100	104	54	92	212	40	14	5X5X29	F07	82	70	70	4	10	
5"	125	130	57	110	232	40	18	5X5X29	F07	82	70	70	4	10	
6"	150	155	57	130	247	40	18	5X5X29	F07	82	70	70	4	10	
8"	200	205	63	180	297	55	22	6X6X44	F07	111	96	102	4	10	
10"	250	225	71	238	350	60	28	8X7X44	F10	132	"4	102	4	10	
12"	300	305	81	275	370	65	32	8X7X44	F10	132	"4	102	4	10	
14"	350	340	92	310	445	80	35	10X8X44	F10	156	136	140	4	10	
16"	400	380	102	325	480	80	40	10X8X69	F14	156	136	140	4	10	
18"	450	430	114	365	510	80	45	14X9X69	F14	156	136	140	4	10	
20"	500	480	127	405	525	95	50	18X11X99	F16	200	180	165	4	10	
22"	550	540	170	410	555	95	60	18X11X99	F16	200	180	165	4	10	
24"	600	590	154	470	580	95	60	18X11X99	F16	200	180	165	4	10	
26"	650	640	210	487	664	95	65	18X11X99	F16	200	180	165	4	10	
28"	700	690	220	510	686	95	70	20X12X99	F25	300	270	254	8	18	
30"	750	736	197	574	735	95	75	20X12X99	F25	300	270	254	8	18	
32"	800	786	190	580	735	95	80	20X14X99	F25	300	270	254	8	18	
36"	900	890	216	678	890	95	90	25X14X119	F30			298	8	22	
40"	1000	980		724	950	95	100	28X16X129	F30			298	8	22	

FULL LUG / FLANGE BODY

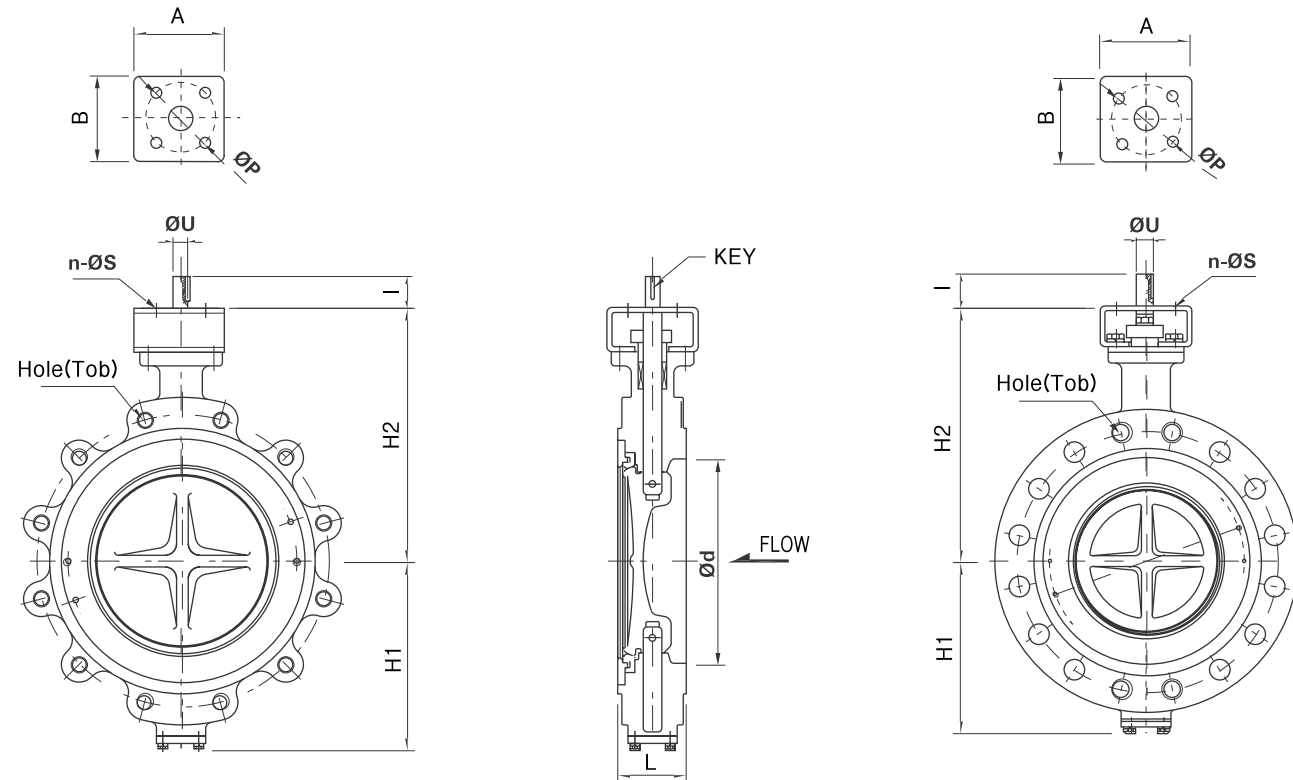

Valve dimensions

Unit(mm)

Size	Inch	mm	Ød	L	H1	H2	Stem			Top flange to ISO 5211				
							I	ØU	Key	Type	A	B	ØP	n
2"	50	55	60	62	182	40	14	5X5X29	F07	82	70	70	4	10
2½"	65	70	48	72	192	40	14	5X5X29	F07	82	70	70	4	10
3"	80	84	48	82	202	40	14	5X5X29	F07	82	70	70	4	10
4"	100	104	54	92	212	40	14	5X5X29	F07	82	70	70	4	10
5"	125	130	57	110	232	40	18	5X5X29	F07	82	70	70	4	10
6"	150	155	57	130	247	40	18	5X5X29	F07	82	70	70	4	10
8"	200	205	63	180	297	55	22	6X6X44	F07	111	96	102	4	10
10"	250	225	71	238	350	60	28	8x7x44	F10	132	114	102	4	10
12"	300	305	81	275	370	65	32	8x7x44	F10	132	114	102	4	10
14"	350	340	92	310	445	80	35	10X8X44	F10	156	136	140	4	10
16"	400	380	102	325	480	80	40	10X8X69	F14	156	136	140	4	10
18"	450	430	114	365	510	80	45	14X9X69	F14	156	136	140	4	10
20"	500	480	127	405	525	95	50	18X11X99	F16	200	180	165	4	10
22"	550	540	170	410	555	95	60	18X11X99	F16	200	180	165	4	10
24"	600	590	154	470	580	95	60	18X11X99	F16	200	180	165	4	10
26"	650	640	210	487	664	95	65	18X11X99	F16	200	180	165	4	10
28"	700	690	220	510	686	95	70	20X12X99	F25	300	270	254	8	18
30"	750	736	197	574	735	95	75	20x12X99	F25	300	270	254	8	18
32"	800	786	190	580	735	95	80	20X14X99	F25	300	270	254	8	18
36"	900	890	216	678	890	95	90	25X14X119	F30			298	8	22
40"	1000	980		724	950	95	100	28X16X129	F30			298	8	22

TRIPLE OFFSET METAL SEAT

Specifications

- Product range**
80mm - 1200mm
- Design standard**
ANSI B16.34 BS5155, MSS SP68, API609
- Flange connections**
API 609, BS 5155, DIN 3840
- Pressure Temperature range**
ASME/ANS116.34
- Face to Face Dimension**
ANSI B16.10 ISO 5752, API 609 BS 5155

Materials

- Body** WCB, Ductile iron, Stainless Steel and As per Customer requirements
- Disc** WCB, Stainless Steel and As per Customer requirements
- Stem** Stainless Steel and As per Customer requirements
- Seat** Stellite overlay, Laminated Metal Seat, Solid Metal Seat and As per Customer requirements

Features

- Zero leakage (bubble tightness)
- Shut off and throttling of gaseous and liquid media
- Low operating torque
- Long service life
- High temperature compatibility



Triple offset Design Principles

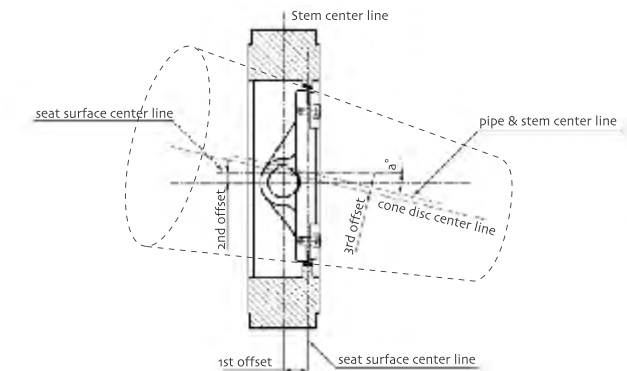

Characteristics and Merits

- Excellent durability of seat part and low operating torque by non-rubbing characteristics with triple offset construction
- Bi-directional zero leakage service by resilient metal sealing and torque seating
- Unrestricted selection of face to face dimensions for API, ASME (ANSI), BS, ISO, etc. and perfect interchangeability of gate, ball, plug, high performance butterfly, and other valves
- Low emission by quarter turn construction and good performance at automation by virtue of low operating torque and low cost
- The valve stem is offset by seat(1st offset) and the valve seat surface center line is offset against the center line of pipe (2nd offset) and the conical axis is offset by valve center line (3rd offset: inclined cone) The 3rd offset completely eliminates rubbing.
- The seat surfaces of body and seal ring in triple offset valve contact with the inclined "cone-in cone" and this design provides excellent sealing and seat part durability by slight wedging effect.

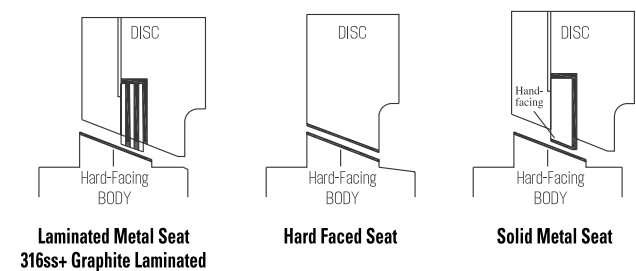

Body Seat

- The valve seat shall be integrated with the body Stellite or stainless steel shall be applied on the seating surfaces of valve body
- The valve seat is designed for inclined cone to ensure non-rubbing, non-jamming, bi-directional shutoff, and zero leakage

Seal Ring (Laminated)

- The seal ring shall be resilient stainless steel lamella, alternated by graphite, aramid fiber and ceramic fiber layers
- The surface contacting between seal ring and body seat is an inclined cone type and the inclined angle generates a slight wedging effect With a seat retainer ring bolted to the disc, the seal ring is fixed to disc not so tightly that it can be replaced easily

150LB / 300LB

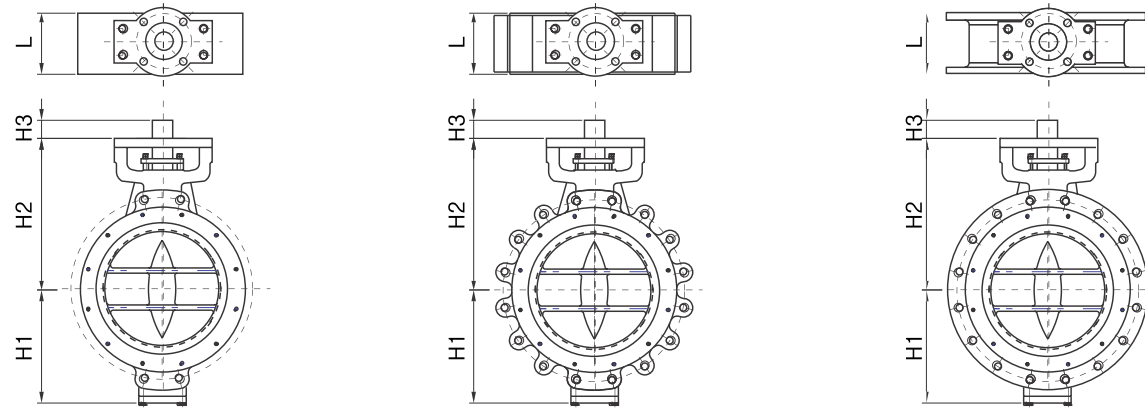

150LB Manual Gear Operating Type

Unit(mm)

Size		H	H1	H2	H3	L (F to F)			P	ØW	WEIGHT (kg)		
Inch	mm					WAFER	LUG	FLANGE			WAFER	LUG	FLANGE
6"	150	300	245	180	35	57	57	140	206	300	20	22	48
8"	200	310	260	195	35	64	64	152	206	300	45	47	89
10"	250	335	285	225	65	71	71	165	206	300	57	61	112
12"	300	390	335	265	80	81	81	178	230	400	85	91	161
14"	350	420	365	290	80	92	92	190	230	400	133	142	228
16"	400	500	435	340	80	102	102	216	279	450	186	199	303
18"	450	515	452	360	80	114	114	222	279	450	213	229	364
20"	500	565	500	395	80	127	127	229	312	560	334	364	499
24"	600	635	570	465	110	154	154	267	312	560	455	492	699
28"	700	775	685	570	130	165	165	292	371	630	718	777	860
30"	750	785	695	600	130	165	165	318	371	630	864	934	1085
32"	800	840	750	630	130	190	190	318	425	710	1090	1119	1241
36"	900	910	820	690	160	200	200	330	425	710	1418	1553	1716
40"	1000	925	835	720	175	216	216	410	425	710	1743	1943	2208
42"	1050	980	860	750	175	251	251	410	513	800	2108	2343	2488
48"	1200	1140	1020	845	200	276	276	470	513	800	3004	3284	3440

Weight and dimensions are approximate

300LB Manual Gear Operating Type

Unit(mm)

Size		H	H1	H2	H3	L (F to F)			P	ØW	WEIGHT (kg)		
Inch	mm					WAFER	LUG	FLANGE			WAFER	LUG	FLANGE
6"	150	330	280	199	65	59	59	140	206	300	36	39	76
8"	200	350	295	218	80	73	73	152	230	400	51	56	93
10"	250	395	340	251	80	83	83	165	230	400	100	112	164
12"	300	450	395	296	80	92	92	178	230	400	134	150	222
14"	350	490	425	331	80	117	117	190	279	450	196	229	298
16"	400	545	480	377	110	133	133	216	279	450	232	277	357
18"	450	605	540	410	110	149	149	222	312	560	360	433	499
20"	500	645	580	440	130	159	159	229	312	560	457	549	621
24"	600	740	650	515	130	181	181	267	371	630	670	805	916
28"	700	910	820	640	200	229	229	292	371	630	1193	1363	1417
30"	750	940	850	690	200	241	241	318	425	710	1463	1658	1715
32"	800	970	880	720	200	241	241	318	425	710	1661	1856	1957
36"	900	1050	960	780	200	260	260	330	425	710	2281	2511	2590
40"	1000	1110	990	800	200	300	300	410	513	800	2214	2425	2585
42"	1050	1160	1050	840	200	300	300	410	513	800	2439	2649	2849
48"	1200	1270	1150	950	250	320	320	470	536	900	3384	3684	4106

Weight and dimensions are approximate

600LB / 900LB

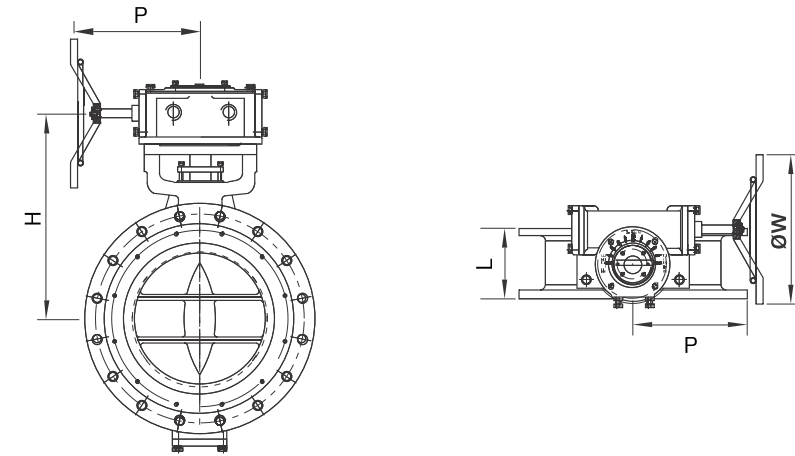

600LB Manual Gear Operating Type

Unit(mm)

Size		H	H1	H2	H3	L (F to F)			P	ØW	WEIGHT (kg)		
Inch	mm					WAFER	LUG	FLANGE			WAFER	LUG	FLANGE
6"	150	365	310	238	80	78	78	210	230	400	65	72	135
8"	200	380	325	248	80	102	102	230	230	400	92	102	162
10"	250	465	400	316	80	117	117	250	279	450	134	187	268
12"	300	520	455	349	110	140	140	270	312	560	224	259	369
14"	350	535	470	374	110	155	155	290	312	560	285	329	364
16"	400	675	585	474	130	178	178	310	371	630	455	520	632
18"	450	715	625	476	130	200	200	330	371	630	555	635	739
20"	500	760	670	504	130	216	216	350	425	710	694	804	879
24"	600	840	750	55	180	232	232	390	425	710	1093	1243	1423

Weight and dimensions are approximate

900LB Manual Gear Operating Type

Unit(mm)

Size		H	H1	H2	H3	L (F to F)			P	ØW	WEIGHT (kg)		
Inch	mm					WAFER	LUG	FLANGE			WAFER	LUG	FLANGE
6"	150	400	335	238	80	104	104	250	279	450	89	100	184
8"	200	445	380	281	80	112	112	310	312	560	134	151	256
10"	250	500	435	358	110	135	135	350	312	560	224	256	425
12"	300	590	500	383	110	170	170	380	371	630	298	352	496
14"	350	635	545	419	130	173	173	400	371	630	376	440	656
16"	400	730	640	455	130	210	210	430	425	710	570	663	834
18"	450	780	690	503	180	228	228	460	425	710	691	824	1044
20"	500	830	710	550	180	250	250	490	513	800	905	1069	1273
24"	600	950	820	656	200	275	275	530	513	800	1317	1704	2506

Weight and dimensions are approximate

* Not specified class and size, please contact sales department

Butterfly valve manufactured according to most severe quality control standards

ANSI	B 16.1	Cast iron pipe flanges and flanged fittings
	B16.5	Steel pipeline flanges
	B 16.34	Steel valves
MSS	SP- 6	Standard finishes for pipe flanges
	SP- 25	Standard marking system for valves
	SP- 44	Steel pipeline flanges
	SP- 55	Quality standard for steel castings
	SP- 61	Pressure testing of steel valves
	SP- 67	narrow (C1-D1) Butterfly valves
	SP- 68	High pressure - offset seat butterfly valve
API	598	Valve inspections and testing
	609	Butterfly valves Wafer and LUG type (face-to-face on valve)
	ISO	7005 Metallic flanges 5208 Industrial valves - pressure testing of valves 5209 General purpose industrial valves - marking 5211/1 Part - turn valve actuator attachment - top flange dimensions
	5752 Tab. 5 (20 series)	Face - to - face and center - to - face dimensions
DIN	3202 - K1	Face - to - face dimensions
	50049 - 2.2	Certificates on material tests (standard)
	50049 - 3.1B	Certificates on material tests (on request)
BS	5155 short	Butterfly valves for general purposes
AWWA	C504	Rubber seated butterfly valves
JIS	B2002	Face to face dimensions
	B2003	valve test
EN	10204	Types of inspection documents

Inspection and testing according as ISO 5208, MSS SP61, AWWA C504, JIS B 2003 API 598 and BS 5155

The body test is performed at 1.5 times of the nominal pressure while the seat test at 1.1 time of the nominal pressure, using for both emulsified water at room temperature. While testing, no leakage shall be noticed from the stems, as for the seat test. For the pneumatic test with closed disc, the butterfly is covered with water and soap on that side where the visual control of the seal is performed, in order to show up a possible leak. DK's valves are tested 100% before delivery.

Seat Leakage Allowance

In accordance with ANSI B 16 -104

Leakage Class Designation	Test Medium	Test Medium	Test Pressure	Testing Procedures Required for Establishing Ration
I	-	-	-	No test required provided user and supplier so agree
II	0.5% of rated capacity	All or water at 50 ~ 125°F (10 ~ 52°C)	45-60psig or max. whichever is lower	Pressure applied to valve inlet, operating differential with outlet open or concerned to a low head loss measuring device, full normal closing thrust provided by actuator.
III	0.1% of rated capacity	As above	As above	As above
IV	0.01% of rated capacity	As above	As above	As above
V	0.05ml per minute of water inch of port diameter per psi differential	Water at 50 ~ 125°F (10 ~ 52°C)	Max. service pressure drop across valve plug not to exceed ANSI body rating (100psi pressure drop minimum)	Pressure applied to valve inlet after filling entire body cavity and connected piping with water and storking valve plug closed. Use net specified max. actuator thrust, but no more, even if available during test Allow time fa leakage flow to be stabilized.
VI	Not to exceed amounts shown in following table based on port diameter	Air or Nitrogen at 50 ~ 125°F (10 ~ 52°C)	50 psig or max. rated across valve plug whichever is lower	Actuator should be adjusted to differential pressure operating full normal closing thrust applied to valve plug seat. Allow time for leakage flow to be stabilized and

Calculated Values of Seat Leakage (Class V)

In accordance with ANSI B 16 - 104, FCI 70-2 (Test Procedure Type B)

Size		ΔP(bar)			Unit(cc/minute)
Inch	mm	10	16	20	
2"	50	0.15	0.24	0.3	
3"	80	0.24	0.38	0.48	
4"	100	0.3	0.48	0.6	
5"	125	0.38	0.6	0.75	
6"	150	0.45	0.72	0.9	
8"	200	0.6	0.96	1.2	
10"	250	0.75	1.2	1.5	

Size		ΔP(bar)			Unit(cc/minute)
Inch	mm	10	16	20	
12"	300	0.9	1.44	1.8	
14"	350	1.05	1.68	2.1	
16"	400	1.2	1.92	2.4	
18"	450	1.35	2.16	2.7	
20"	500	1.5	2.4	3.0	
22"	550	1.65	2.64	3.3	
24"	600	1.8	2.88	3.6	

Qa(allowable leakage) (cc/minute) = 3×10^{-4} , nominal size (mm) x Δ P(bar) or 0.0075 nominal size (inch) x Δ P(bar)
 Δ P = max. differential pressure

FLANGE STANDARD COMPARISON

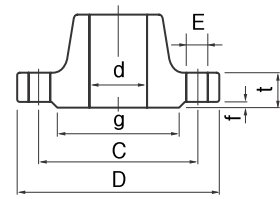

5. 10. 16
JIS 20, 30, 40, 63K

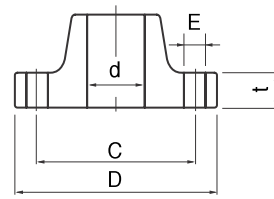

ANSI 125
BRONZE FLANGES : ANSI 150 & 300

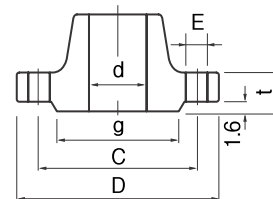

ANSI 150

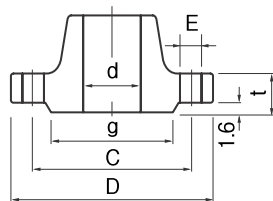

ANSI 250, 300

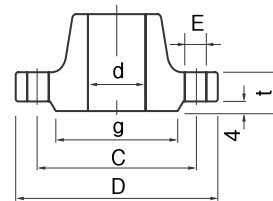

ANSI 400, 600, 900

Flange drillings

Size	JIS 5K		JIS 10K		JIS 16K		BS 4504 PN 10		BS 4504 PN 16		ANSI CLASS 125LB		ANSI 150LB									
	Inch	mm	ØC	F	ØE	ØC	F	ØE	ØC	F	ØE	ØC	F	ØE	ØC	F	ØE					
1½"	40	95	4	15	105	4	19	105	4	19	110	4	18	110	4	18	98	4	16	98.5	4	16
2"	50	105	4	15	120	4	19	120	8	19	125	4	18	125	4	18	121	4	20	120.5	4	19
2½"	65	130	4	15	140	4	19	140	8	19	145	4	18	145	4	18	140	4	20	139.5	4	19
3"	80	145	4	19	150	8	19	160	8	23	160	8	18	160	8	18	152	4	20	152.5	4	19
4"	100	165	8	19	175	8	19	185	8	23	180	8	18	180	8	18	191	8	20	190.5	8	19
5"	125	200	8	19	210	8	23	225	8	25	210	8	18	210	8	18	216	8	23	216	8	22
6"	150	230	8	19	240	8	23	260	12	25	240	8	18	240	8	23	241	8	23	241.5	8	22
8"	200	280	8	23	290	12	23	305	12	25	295	8	23	295	12	23	299	8	23	298.5	8	22
10"	250	345	12	23	355	12	25	380	12	27	350	12	23	355	12	27	362	12	26	362	12	25
12"	300	390	12	23	400	16	25	430	16	27	400	12	23	410	12	27	432	12	26	432	12	25
14"	350	435	12	25	445	16	25	480	16	33	460	16	23	470	16	27	-	-	-	476	12	29
16"	400	495	16	25	510	16	27	540	16	33	515	16	27	525	16	30	-	-	-	539.5	16	29
18"	450	555	16	25	565	20	27	605	20	33	565	20	27	585	20	31	-	-	-	578	16	32
20"	500	605	20	25	620	20	27	660	20	33	620	20	27	650	20	33	-	-	-	635	20	32
24"	600	715	20	27	730	24	33	770	24	39	725	20	30	770	20	36	-	-	-	749.5	20	35
28"	700	820	24	27	840	24	33	875	24	42	840	24	30	840	24	36	-	-	-	863.6	28	35
30"	750	880	24	33	900	24	33	935	24	42	-	-	30	-	-	-	-	-	-	914.4	28	35
32"	800	930	24	33	950	28	33	990	24	48	950	24	33	950	24	39	-	-	-	978	28	41
36"	900	1030	24	33	1050	28	33	1090	28	48	1050	28	33	1050	28	39	-	-	-	1086	32	41
40"	1000	1130	28	33	1160	28	39	1210	28	56	1160	28	36	1170	28	42	-	-	-	1200	36	41

ØC : Bolt Circle Diameter

F : Number of holes

ØE : Diameter of holes

Operating Characteristics For Sizing

Torques for resilient seated butterfly valve

The factors affect the torque required to operate the valves

- Valve diameter
- Shaft diameter
- Bearing friction coefficient
- Type of seat material

Size	Inch	mm	1½"	2"	2½"	3"	4"	5"	6"	8"	10"	12"	14"	16"	18"	20"	24"	28"	30"	32"	36"	40"	
Shut off Pressure	3.5Bar		10	12	11	23	41	38	83	156	243	342	488	667	887	1146	2386	2710	3000	3540	4640	6300	
in Bar	6Bar		10	11	23	33	40	66	91	170	276	389	544	762	1023	1322	2781	3300	3940	4340	5360	7800	
	10Bar		13	23	28	31	52	74	109	180	320	484	680	880	1261	1630	3256	4050	4590	4990	6940	9940	
	16Bar		14	23	29	37	39	89	126	260	390	560	820	1120	1520	2030	2493	3076	4150	5650	6040	6640	9490

Unit(N.m)

Torques For High Performance(Double Eccentric)

Size	Inch	mm	2"	2½"	3"	4"	5"	6"	8"	10"	12"	14"	16"	18"	20"	24"	28"	32"	36"	40"		
1000																						
Class 150	10 Bar		2.3	2.5	2.7	4.2	9.0	11.2	21.3	34.0	49.2	86.4	119.2	146.3	190.1	302.9	350.1	715.1	917			
1070																						
Differential Pressure (Bar)	16 Bar		3.0	3.4	3.6	5.8	11.3	14	24.6	41.2	60.3	105	144	183	235.2	374.4	432.2	917.7	1214.5			
Class 300	10 Bar		2.3	3.0	3.8	5.4	12.1	14.0	28.0	43.0	65.2	95.8	136.8	173.0	238.3	372.3						

Unit(kgf.m)

Triple Offset Torque

Size	Inch	mm	3"	4"	5"	6"	8"	10"	12"	14"	16"	18"	20"	24"
Differential Pressure	10Bar		30	53	73	118	204	319	549	661	927	1540	1949	2921
in Bar	20Bar		35	104	144	234	403	633	1087	1310	1836	3050	3859	5784
	30Bar		118	206	286	463	799	1252	2152	2593	3635	6039	7640	11452
	52Bar		233	408	566	916	1581	2480	4260	5134	7198	11958	15128	22675

Unit(N.m)

The torque is actuator sizing torque at pressure differential.

Minimum 20% additional safety factor to be considered and hydrodynamic torque may be considered at given flow condition

Torque Conversion Ratio

N.m	KN.m	Factors		
		Kgf.m	lbf.in	lbf.ft
1	0.001	0.102	8.85	0.738
1000	1	101.972	8851	737.6
9.807	0.0098	1	86.8	7.233
0.113	1,13 x 10 ⁻⁴	0.01155	1	0.083
1.356	0.0014	0.138	12	1

Torque To Be Considered

Torque plays an important part in the cost, operation and life span of butterfly valves. The following explains why. Bearing friction, seal or seating friction, and fluid dynamic effects on the disc are primary factors in determining requirements for a butterfly valve. These are described below. Any unbalanced pressure across the butterfly valve disc places a direct load on the shaft bearings. The projected area of the disc decreases with valve opening, this bearing friction varies from maximum as the disc rotates from the closed to the fully open position.

Seating friction is maximum during the first few degrees of opening (or the last few degrees of closing) and is the result of the valve disc edge action against the seat. The seating torque acts to oppose the rotation of the disc. The contact of the seat around the full periphery of the disc creates the bubble tight seal.

From the dynamic standpoint, a butterfly valve disc is torque balanced only when totally closed for fully open. In all intermediate positions, a fluid dynamic torque is present because the fluid velocity over the disc surface is always higher on the trailing edge of the disc than on the leading edge. This torque acts in a valve "disc - closing" direction, tending to reach its highest point at about 70 degrees open.

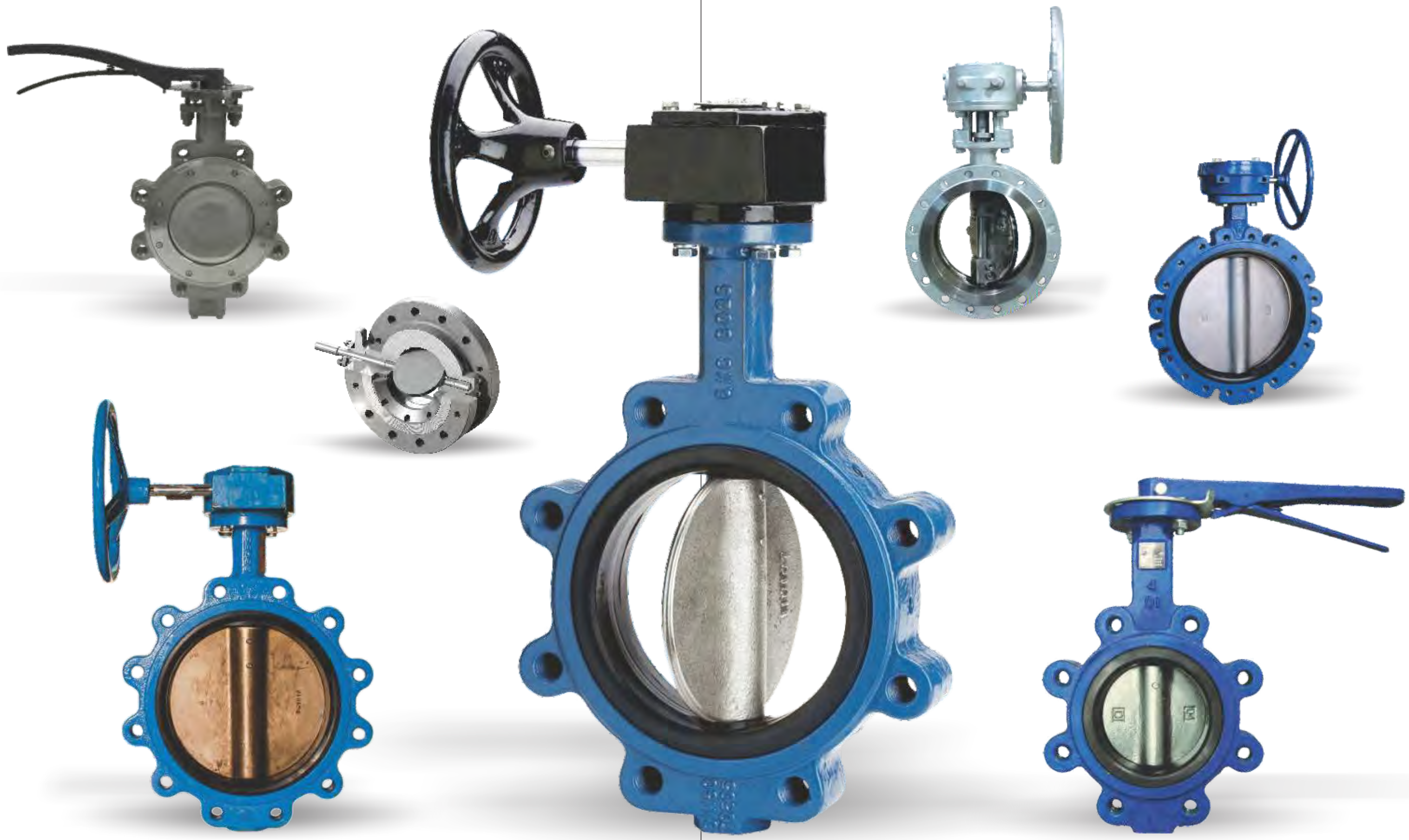



Jayant Engineering & Marketing Pvt. Ltd.
Regd. Office & Works: Plot No. 2003/2004, Phase II,
G.I.D.C. Chhatral, Ta. Kalol, Dist. Gandhinagar, Gujarat 382729, India.
Ph.: +91 2764 234053, 232182, Fax: +91 2764 233169
Email: sales@jayantvalves.com
www.jayantvalves.com